



Humidity Corrections in TiMREX Upper-Air Soundings and Their Impact on Convective Parameters

21 October 2009

*Paul Ciesielski, Richard Johnson, Ben Jou,
Po-Hsiung Lin, Wen-Ming Chang, Ching-
Hwang Liu and Shao-Chin Huang*

TiMREX Sounding Network

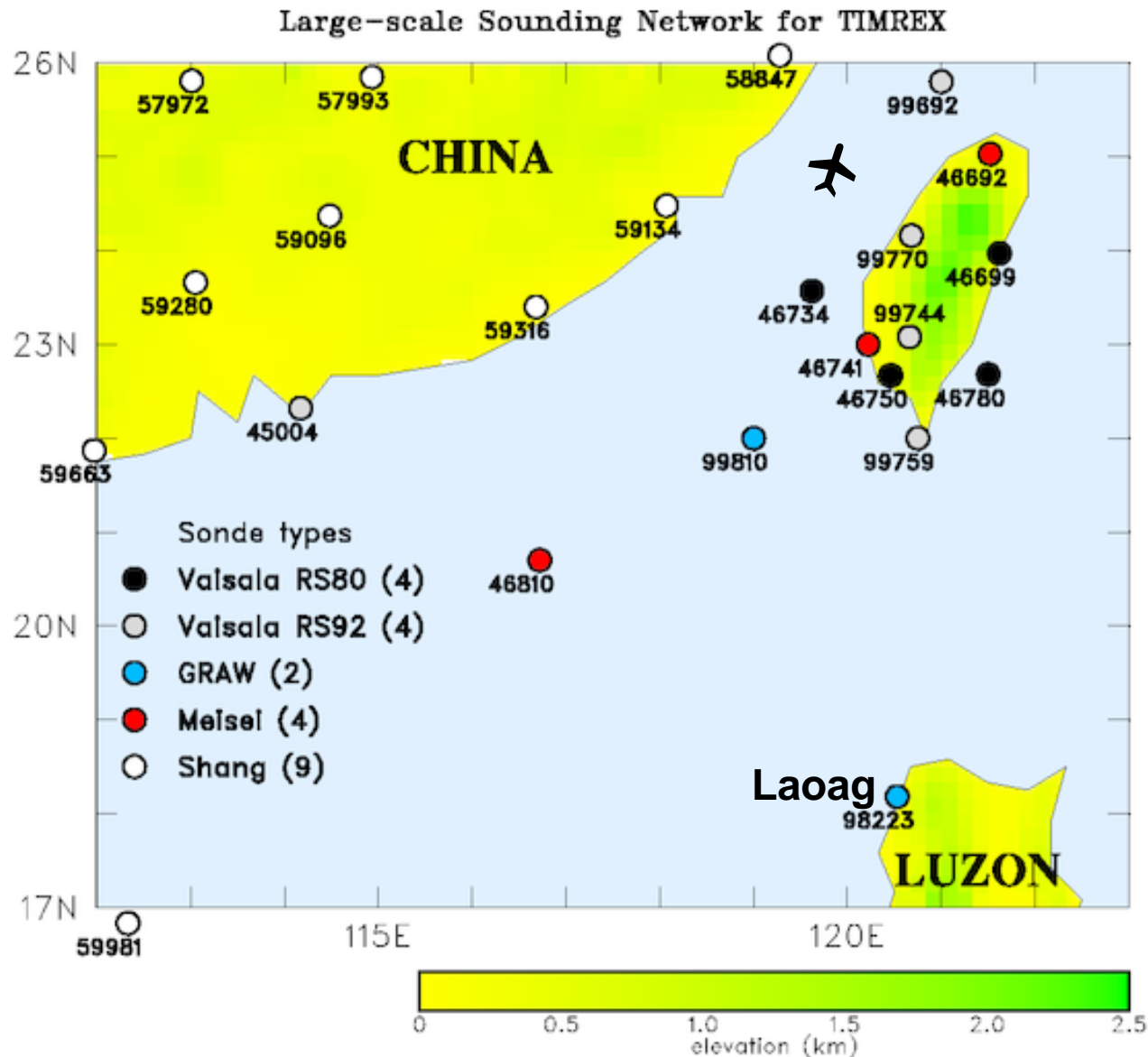

- 5 different sounding types used in TiMREX
- Taiwan was responsible for 13 sites including Laoag which went to 2x daily sondes on 1 June
- 15 dropsonde missions were flown (190 drops)
- In total, 2330 sonde observations were made during TiMREX (15 May - 25 June 2008)

Evidence for sonde RH biases can be identified by comparing sonde data to independent measurements of humidity.

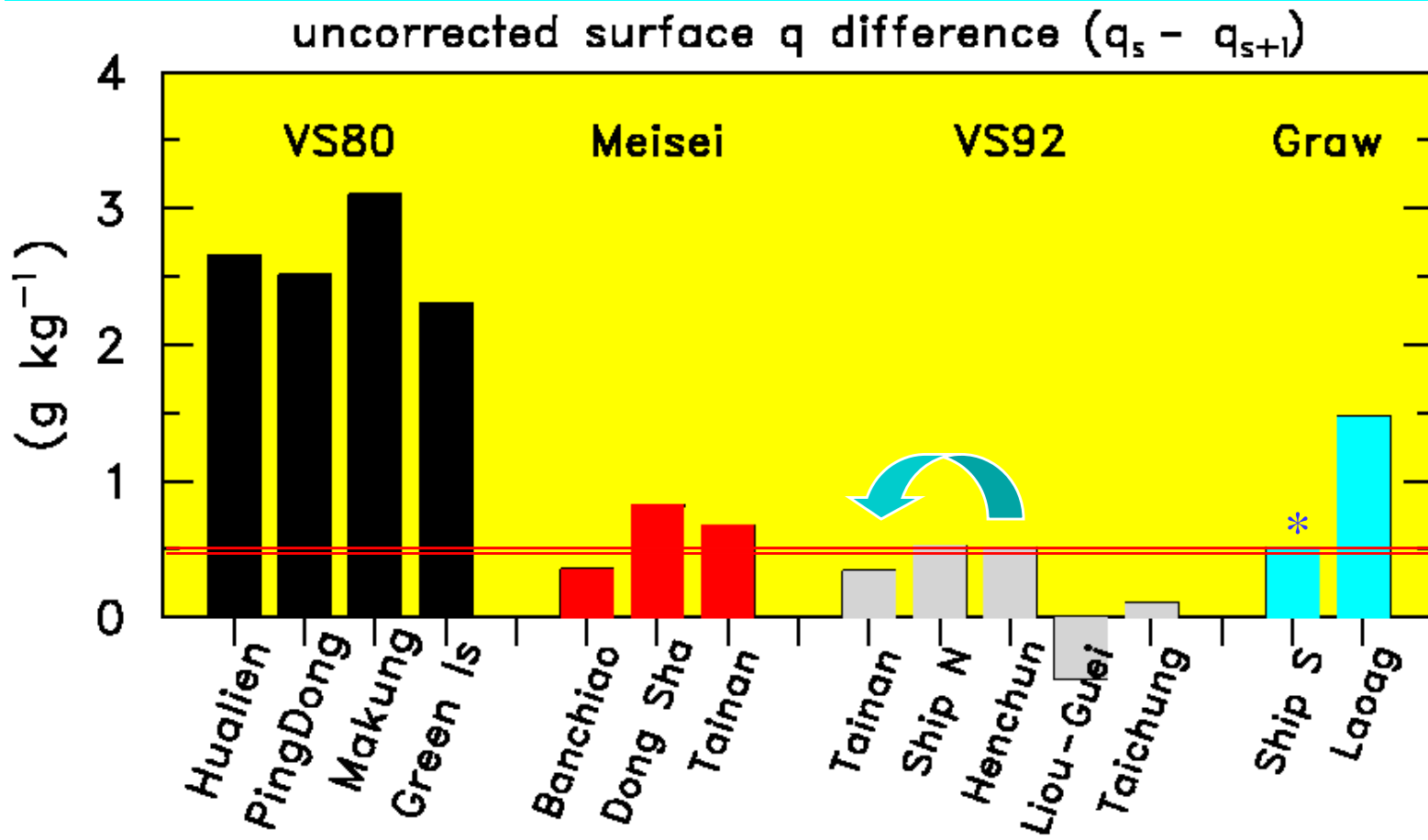

- Difference between sonde q at first point above the sfc to independent sfc. measurement of q
- realistic values should be < 0.5

- VS80 sites have mean $\Delta q > 2$ indicating large low-level sonde dry bias
- Δq at MS80 sites and Laoag suggest a slight dry bias
- Δq at VS92 sites looks reasonable; negative value at Liou-Guei is related to how sfc obs was taken

Comparison of sonde PW to independent observations

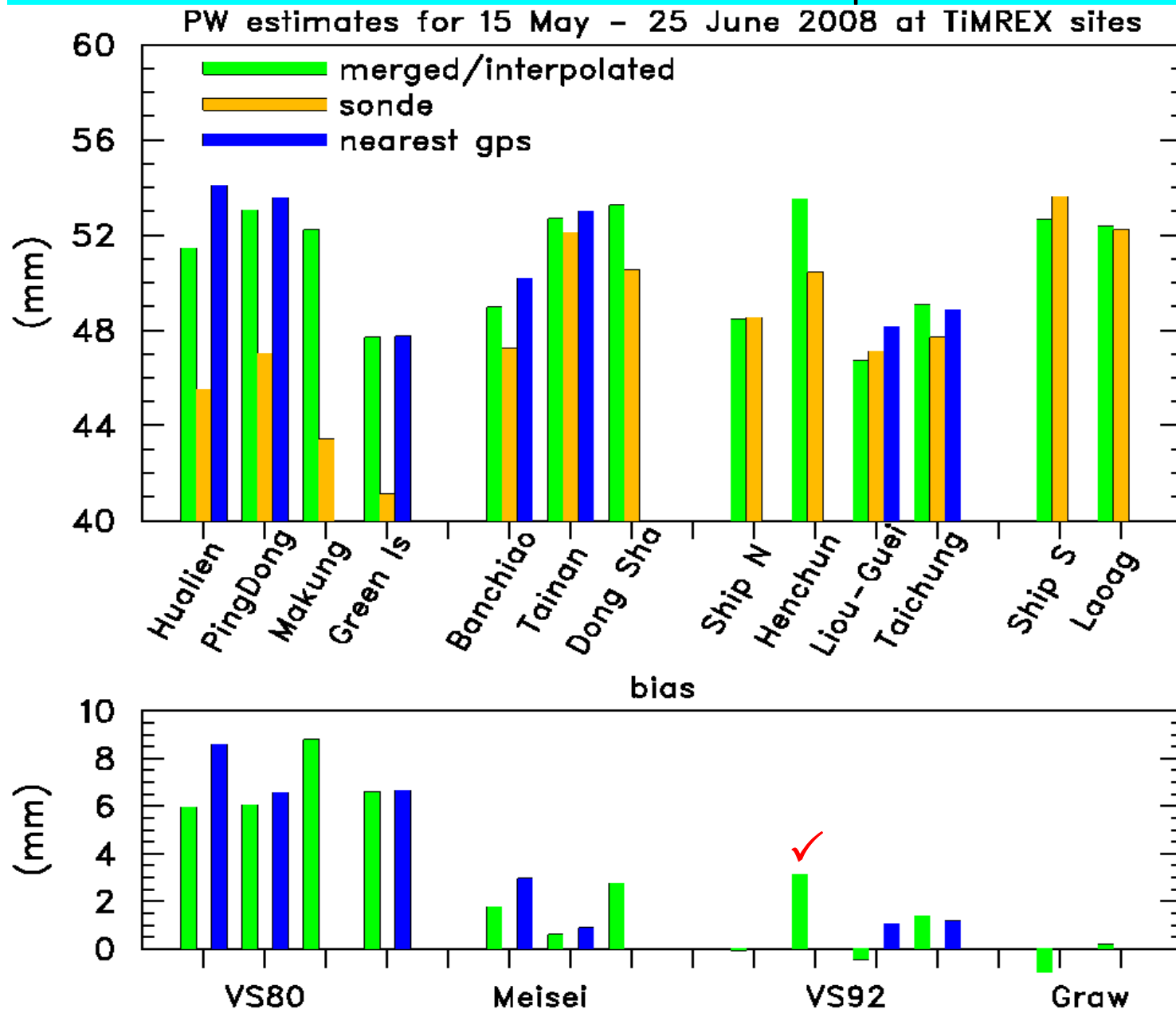

- Independent obs (ground based GPS or AMSE retrievals over oceans); an accuracy of 1-2 mm
- In cases with elevation differences > 50 m, non-sonde were adjusted by an appropriate scaling.
- Dry bias on the order of 12-20% present in VS80 sondes.
- Dry bias of 3-5% in Meisei sonde
- Little or no bias present in VS92 and Graw sondes.

✓ Indicates that a more careful comparison is needed

Further evidence for sonde RH biases

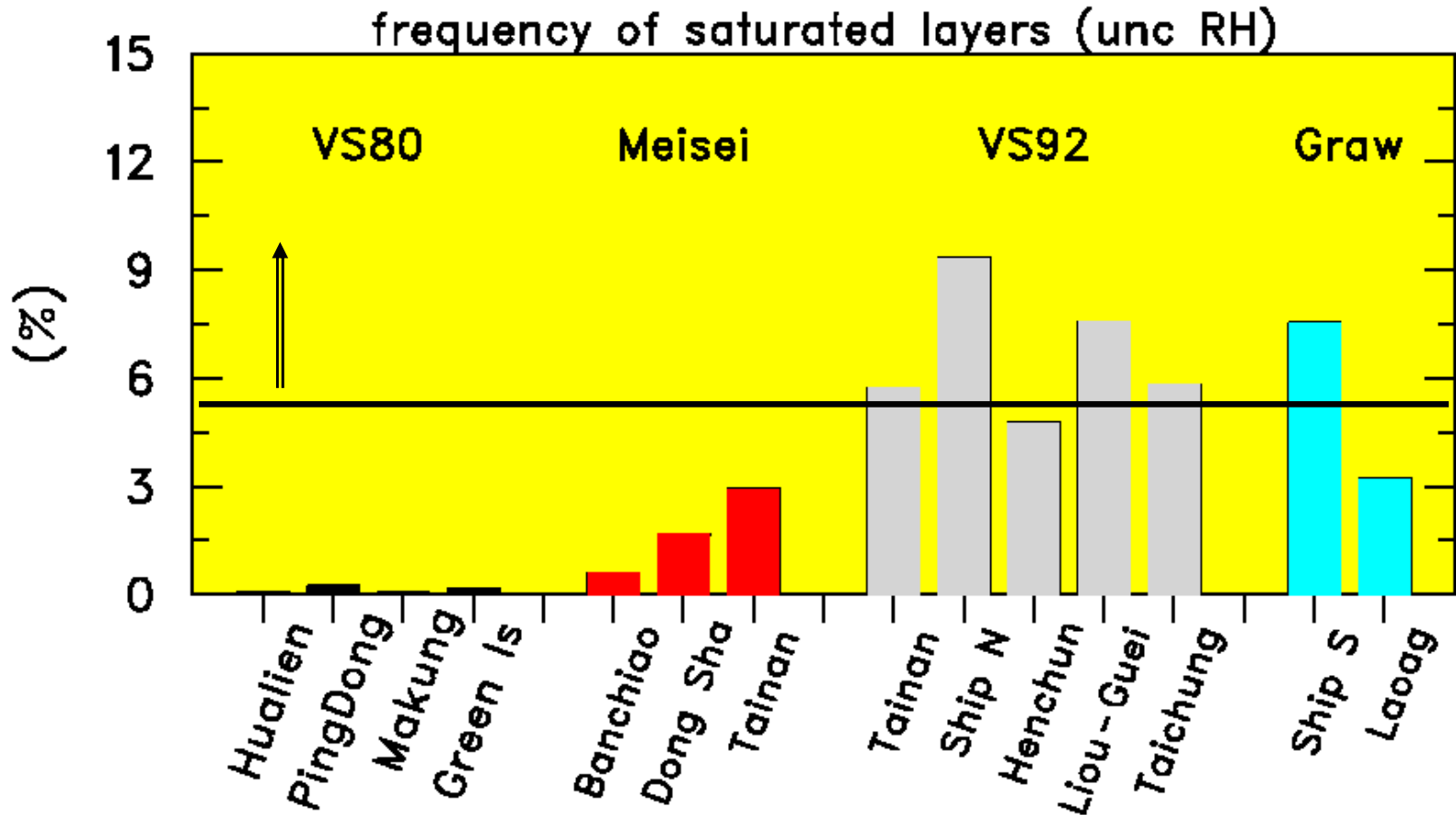

VS80
have large
a dry bias

MS80
appear to
have
slight dry
bias

VS92 have
slight
daytime
dry bias

S.Ship
looks
okay;
Laoag
appears
slightly
dry

- In other monsoon-type experiments (e.g. NAME) the freq. of saturated layers in soundings has been observed to be on the order of 5-10%
- Only the VS92 sites and S. Ship are in this range.

Summary of corrections used at each site

Stn. ID	Stn. name	Sonde type	Correction applied
46699	Hualien	VS80	CDF VS80/VS92, CP92
46734	Makung	VS80	VCC, CP80
46750	Pingdong	VS80	VCC, CP80
46780	Green Is.	VS80	VCC, CP80
46692	Banchiao	MS80	CDF MS80/VS92, VON
46810	Dongsha	MS80	CDF MS80/VS92, VON
46741	Tainan	MS80	CDF MS80/VS92, VON
“	“	VS92	VON
99692	N. Ship	VS92	VON
99744	Liou-Guei	VS92	VON
99759	Henchun	VS92	VON
99770	Taichung	VS92	VON
99823	Laoag	GRAW	CDF GRAW/VS92, VON
99810	S.W. Ship	GRAW	none
99999	Dropsondes	VS92	none

Ultimately, the correction chosen at each site was the one that provided the best validation to independent data.

Corrections used at VS80 sites

Stn. ID	Stn. name	Sonde type	Correction applied
46699	Hualien	VS80	CDF VS80/VS92, CP92
46734	Makung	VS80	VCC, CP80
46750	Pingdong	VS80	VCC, CP80
46780	Green Is.	VS80	VCC, CP80

- Choice of using CDF matching method using Pingdong intercomparison dataset (18 launches) **or** Vaisala Corrected Coefficients (VCC)
- The Vaisala company took a sample of 70 sondes from these sites, determined that the bias at three of the sites (Pingdong, Makung and Green Is) was indeed beyond what was typical, and created a set of corrected coefs. (*thanks to Dr. Lin, Po-Hisung*).
- Analyses showed VCC provided slightly better validation at Pingdong than CDF, so VCC was used at all these sites but Hualien
- A method proposed by Cady-Pereira (CP) et al. (2008) was used to correct for daytime dry bias, this is a height independent correction, being only a function of solar zenith angle; is slightly larger in VS92 sondes

Corrections used at VS92 sites

Stn. ID	Stn. name	Sonde type	Correction applied
46741	Tainan	VS92	VON
99692	N. Ship	VS92	VON
99744	Liou-Guei	VS92	VON
99759	Henchun	VS92	VON
99770	Taichung	VS92	VON

- of the many corrections proposed for VS92 sondes, the most appropriate comes from Yoneyama's et al 2009 (YON) study based on sondes taken in an oceanic, convective environment.

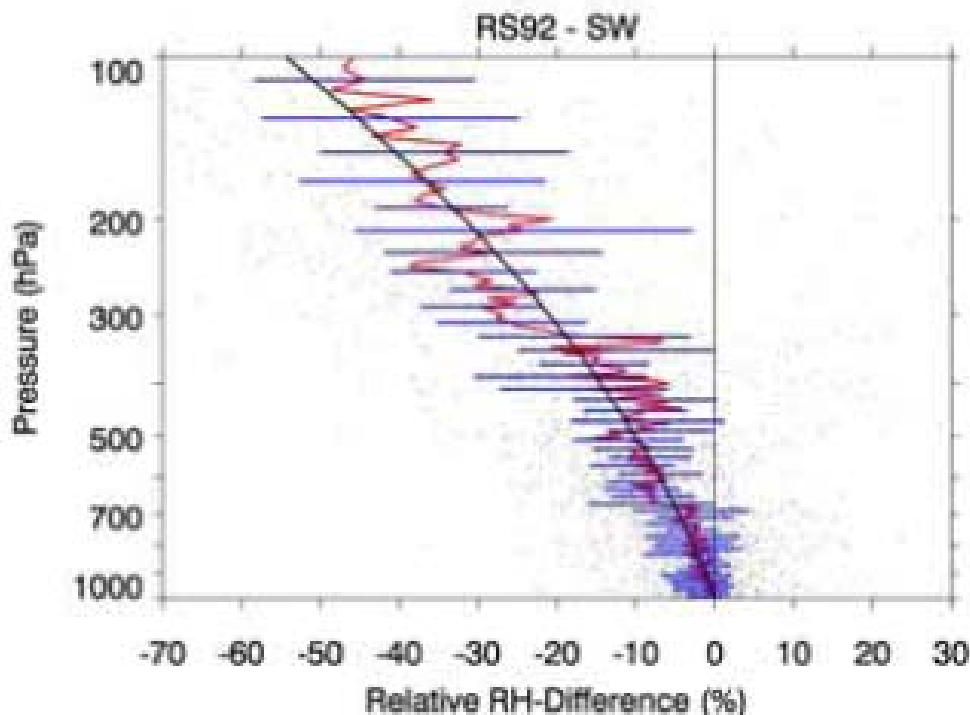

- smooth curve is a polynomial fit to the red line (VS92-SW RH difference based on 14 intercomparison launches)
- correction is function of solar zenith angle and height with correction near the surface but increasing with height

Corrections used at MS80 and Graw sites

Stn. ID	Stn. name	Sonde type	Correction applied
46692	Banchiao	MS80	CDF MS80/VS92, VON
46810	Dongsha	MS80	CDF MS80/VS92, VON
46741	Tainan	MS80	CDF MS80/VS92, VON
99823	Laoag	GRAW	CDF GRAW/VS92, VON

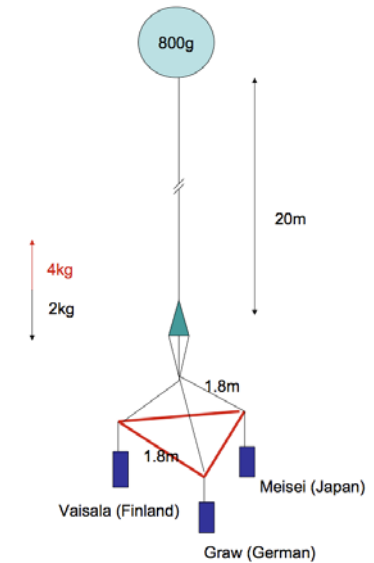

- corrections used CDF matching method based on Banchiao intercomparison data set (12 launches in non-monsoonal conditions comparing VS92, MS80 and Graw).

Dataset was less than optimal.

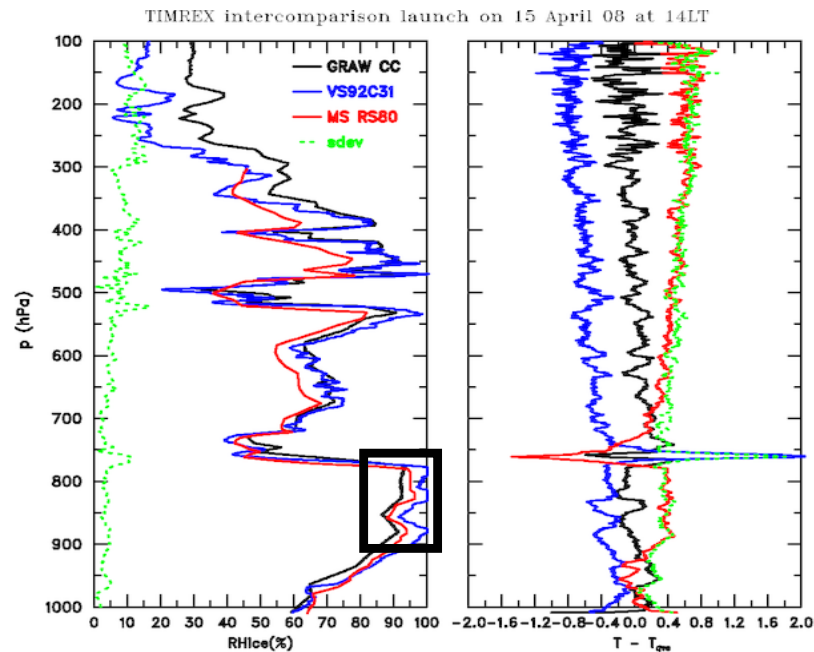

- Results from intercomparison showed small differences in winds and temps (0.5C at low levels to 1.5C aloft)
- Slight dry bias at high RH (3-5%) with only VS92 sondes attaining saturation in clouds.

Impact of corrections on mean RH_{ice} and q (specific humidity) profiles

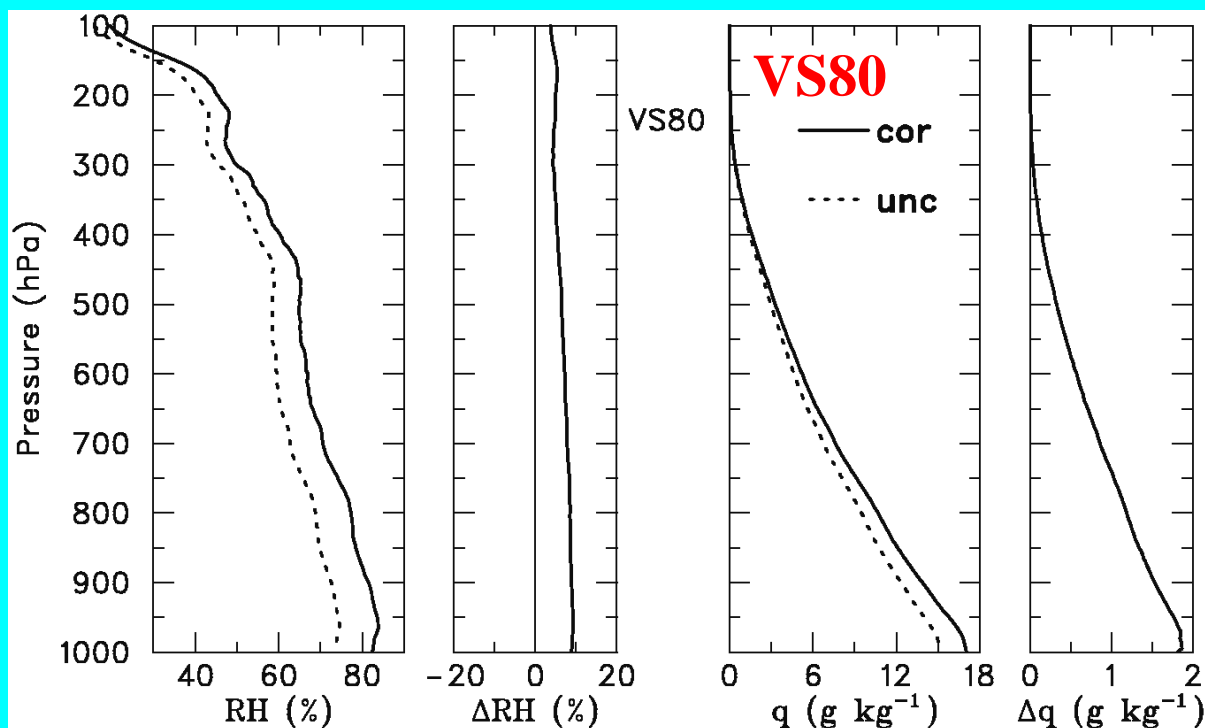

- **VS80** sondes show mean RH increase of about 10%; ~2 g/kg in terms of q in BL but decreasing with height.
- Corrected BL: 82% RH, 17 g/kg quite similar to VS92 sondes

- Impact of correction on **VS92** sondes is minimal at low levels but increases mean RH ~15-20% at upper levels up to 75%; small q increase (0.2 g/kg) at mid levels.

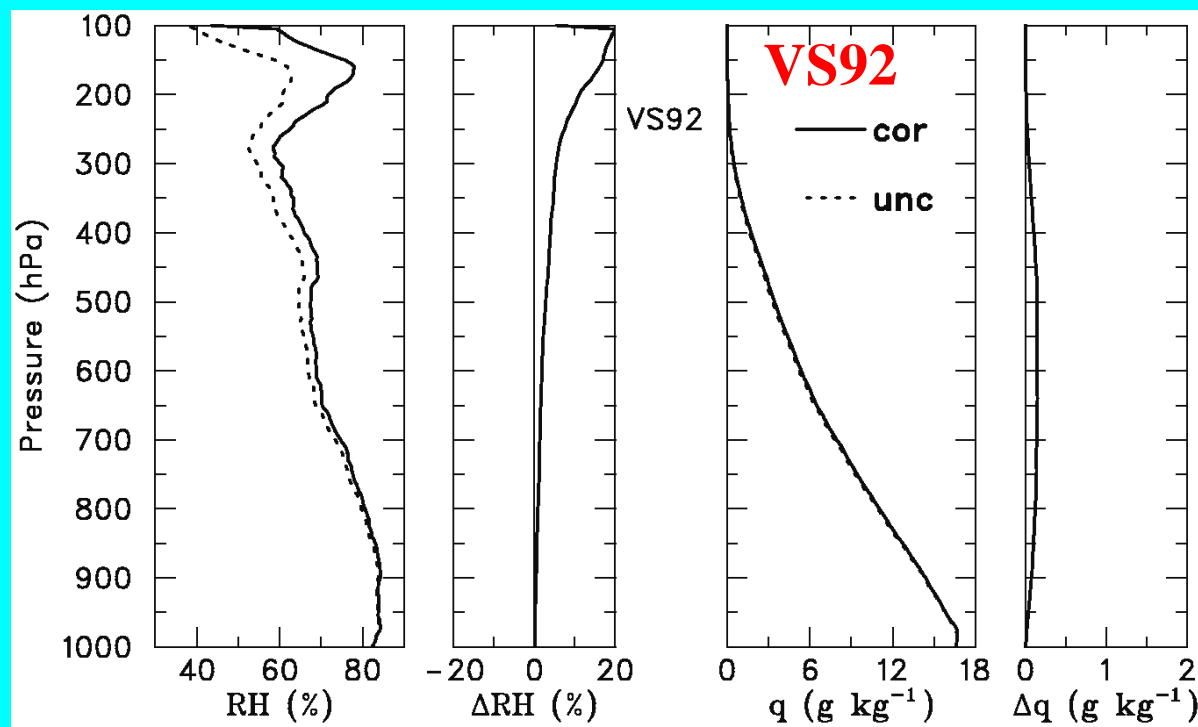

Impact of correction on mean RH and q profiles (cont.)

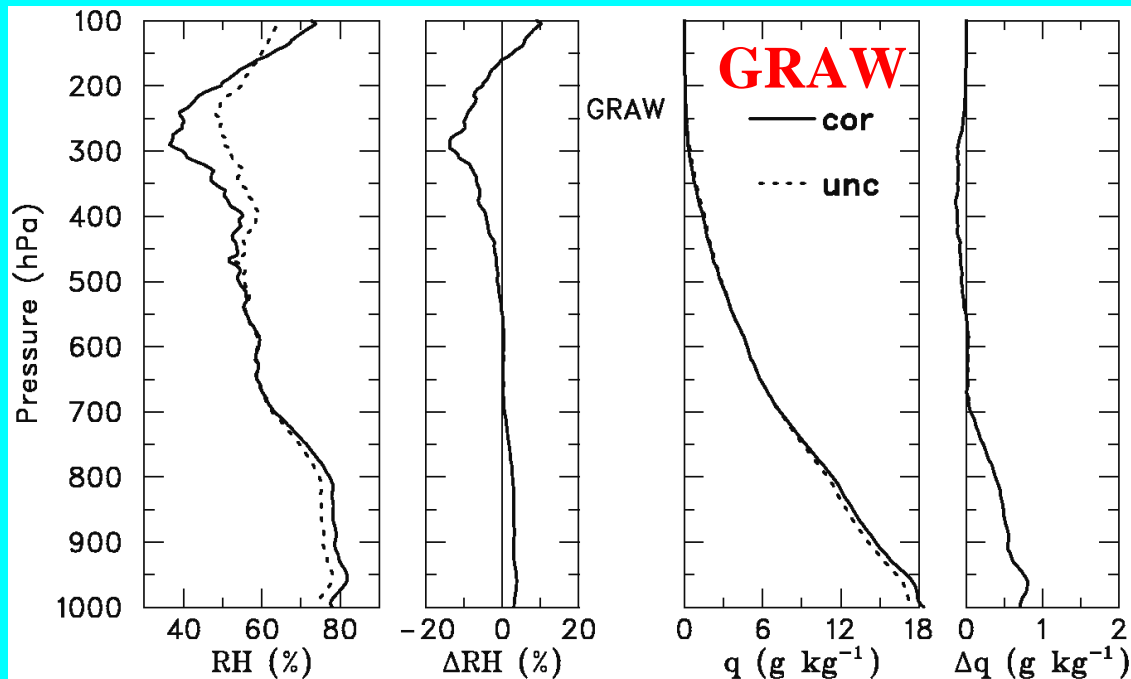
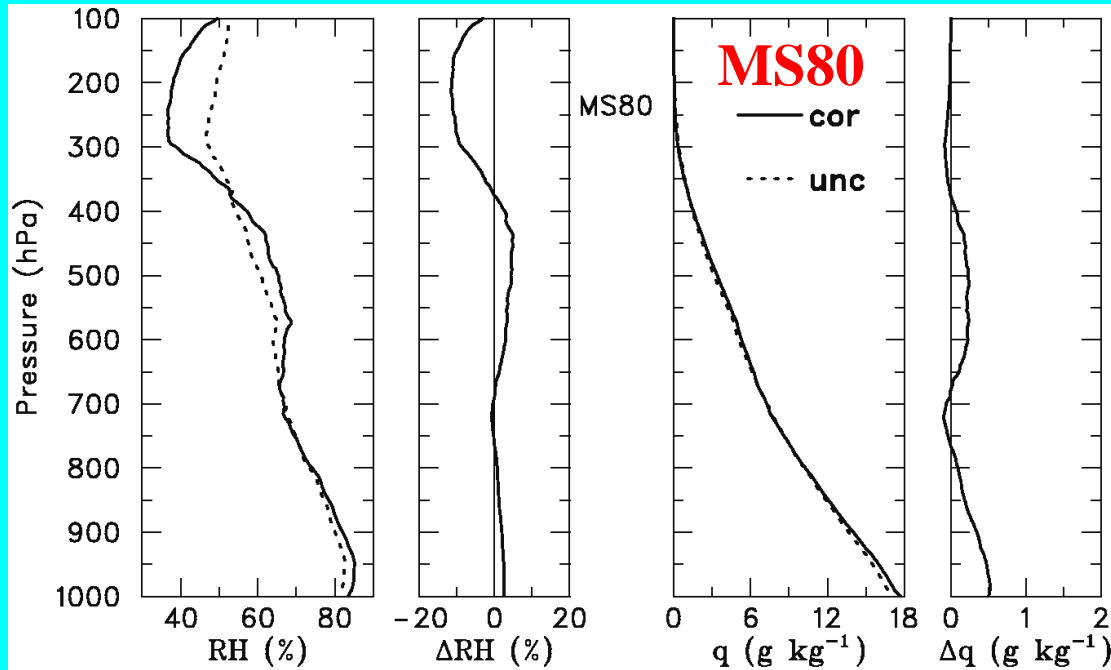

- For both the MS80 and GRAW sondes the correction increases the low-level RH from 3-5% (~0.5 g/kg), at upper levels the correction results in a slight drying.

Impact of correction on near surface q gradient

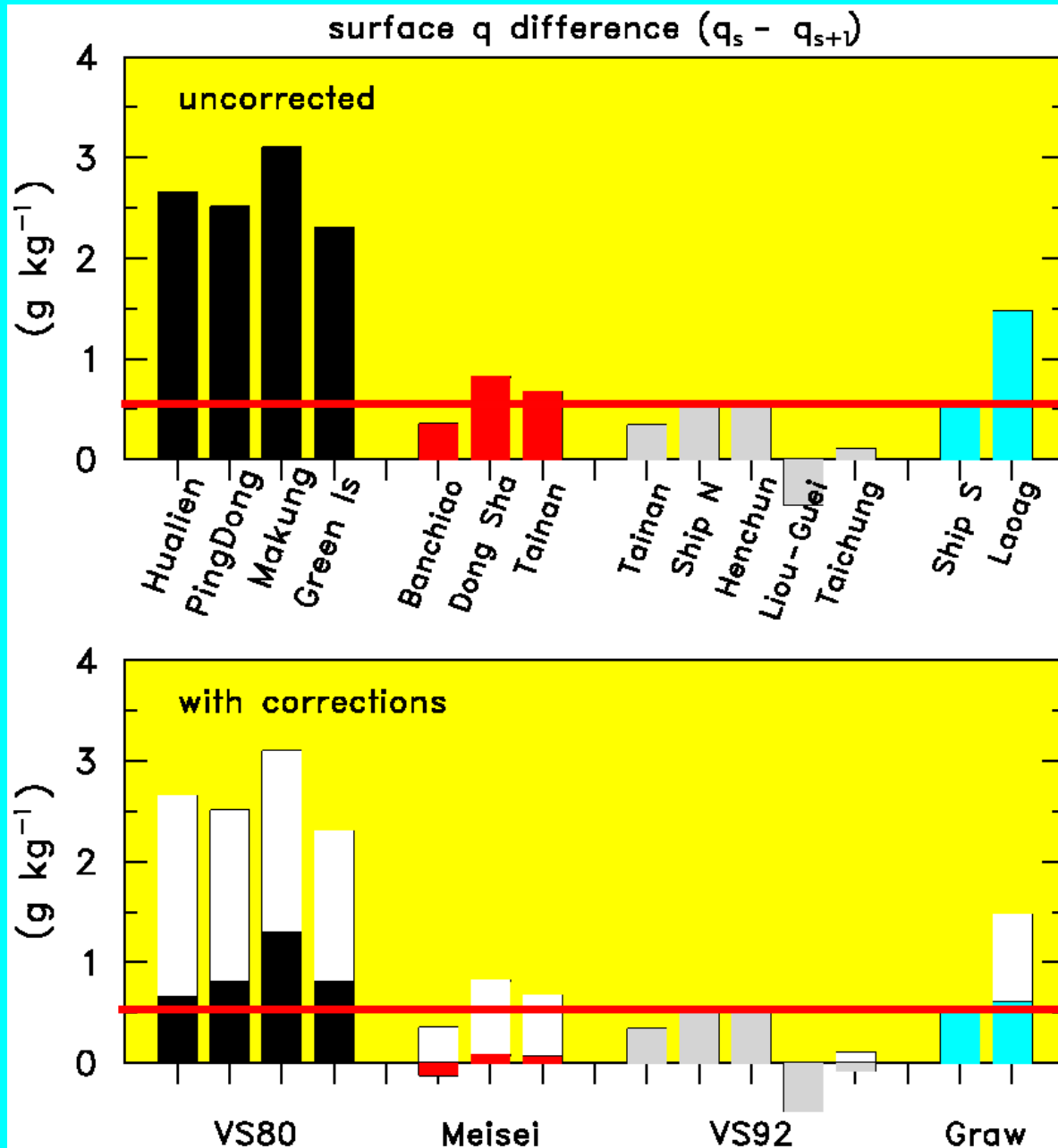

- Near surface moisture gradients computed with corrected data now show values much closer to the range of expected values (< 0.5).
- the corrected VS80 sites may still be slightly too dry but are greatly improved from their uncorrected values

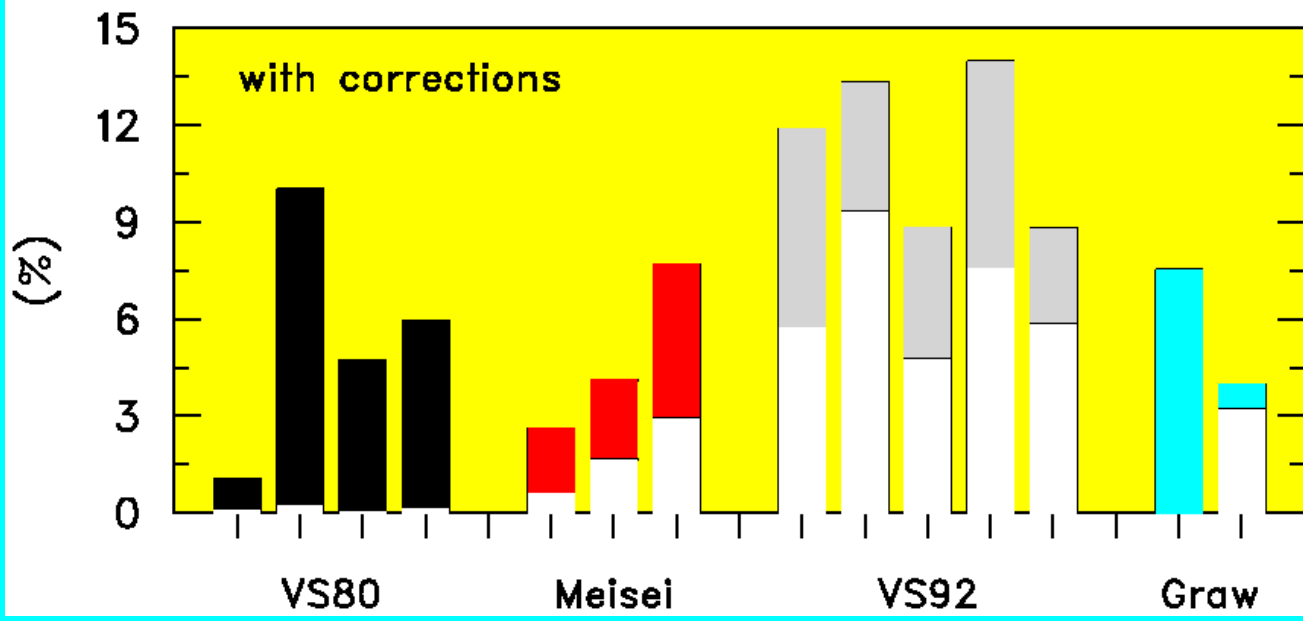
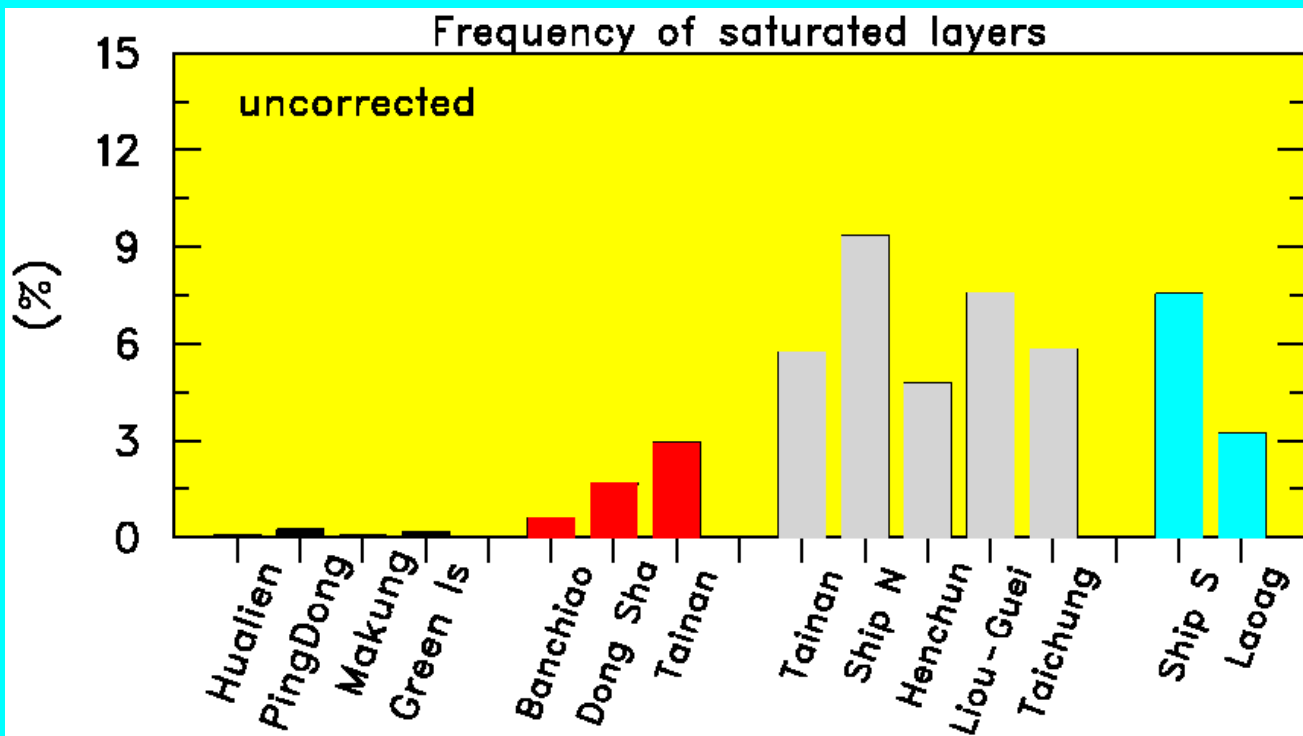

- With the correction, the frequency of saturated layers has been increased at all sites with percentages more reasonable for a monsoon environment
- For example, the frequency at Pingdong increased from 0.2% to ~10%.
- Frequency at Hualien (~1%) still appears to be too low.

Impact of correction on PW

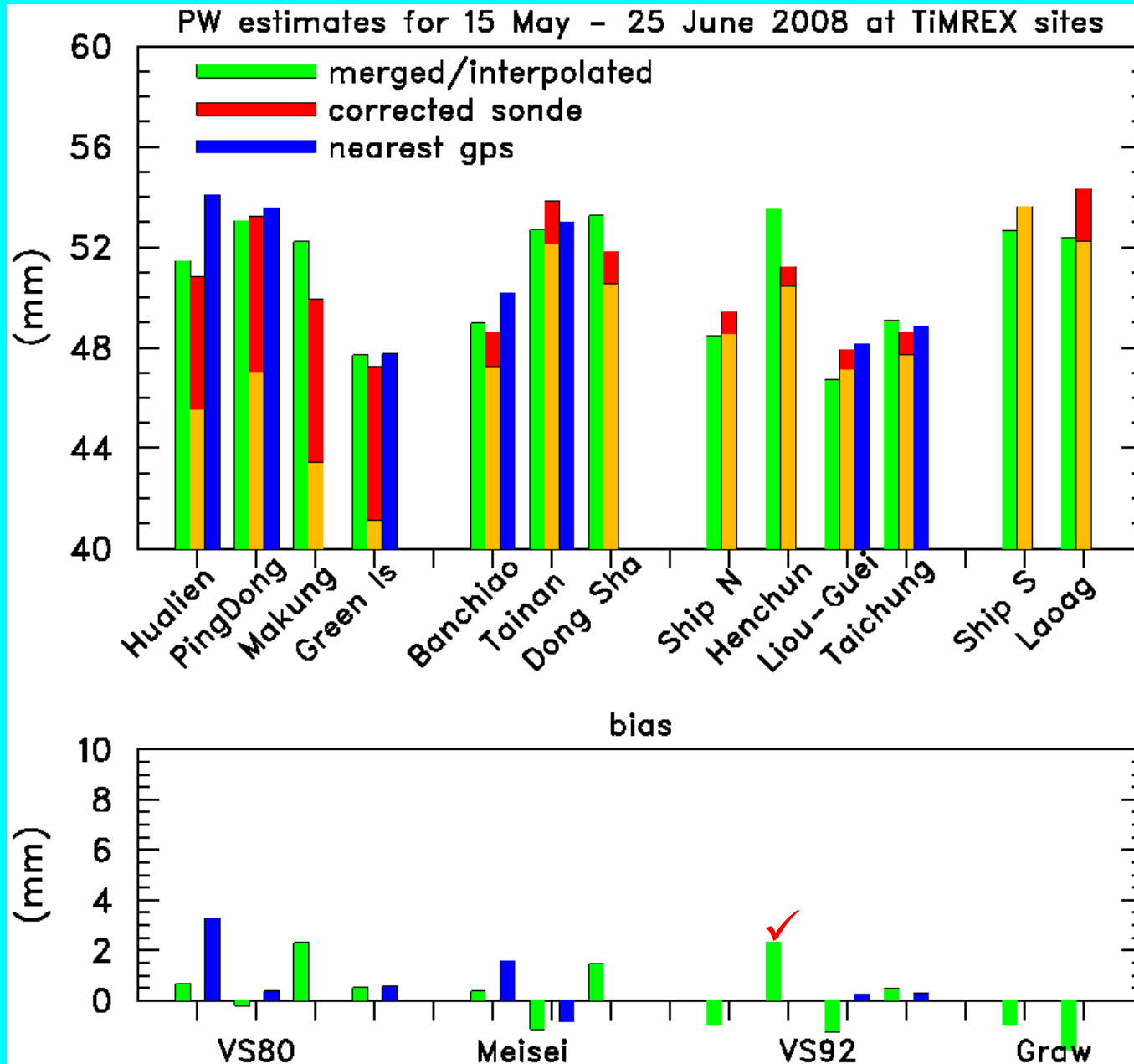

- Red bars show increase in PW due to correction.

- Corrected values are now close to or within uncertainty limits of independent estimates (1-2 mm).

- Main exception is at Hualien which appears to be under corrected (still too dry).

Validation of humidity correction at Pingdong

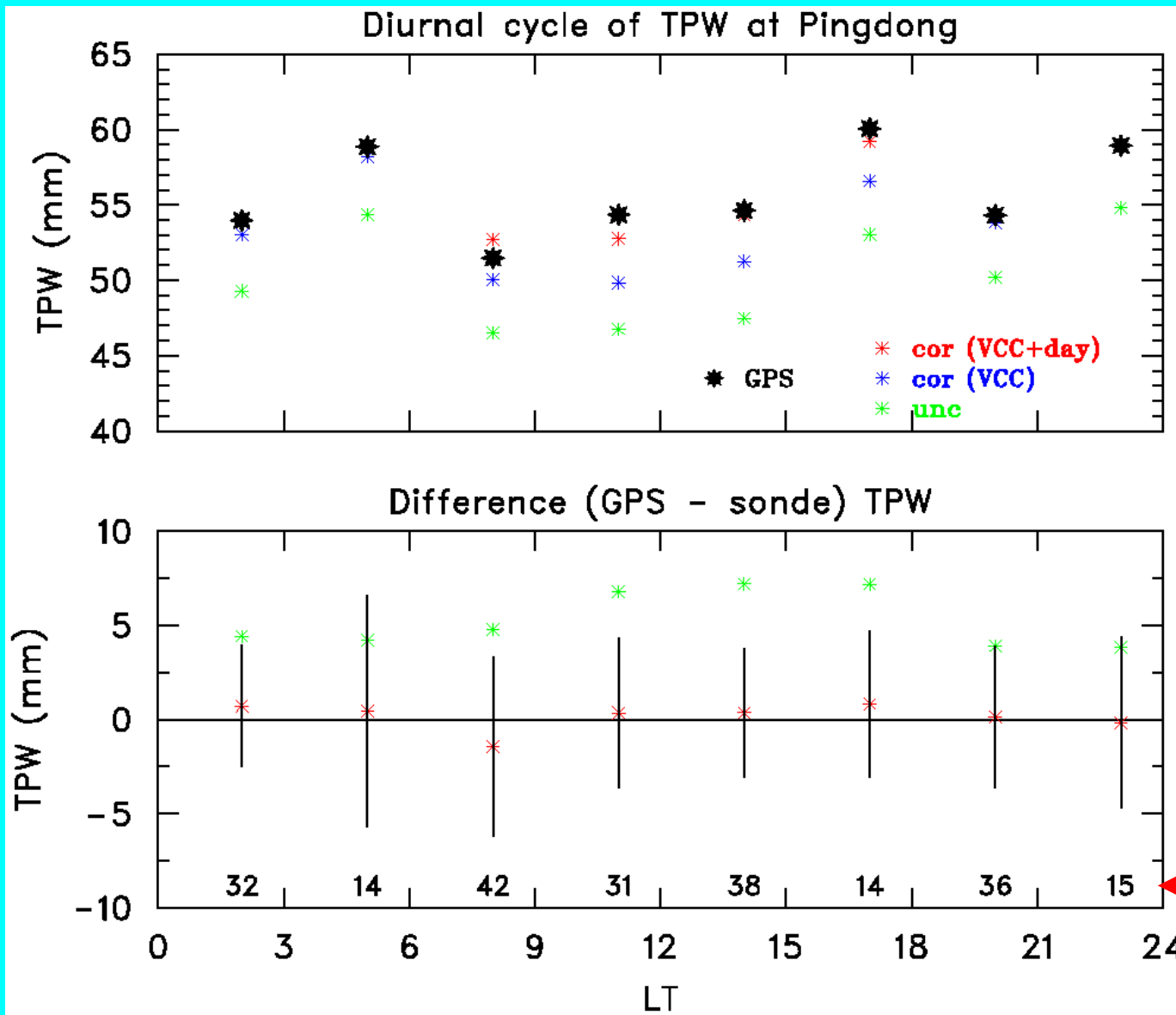

- Correction results in an excellent match between corrected sonde PW and nearby GPS site ($r = 0.89$).

$$\overline{PW}_{GPS} - \overline{PW}_{sonde} = 0.45\text{mm}$$

- PW differences at individual time of day are reduced from 5-8 mm to less than 1mm.

← # of obs at each time

Validation of humidity correction at Hualien

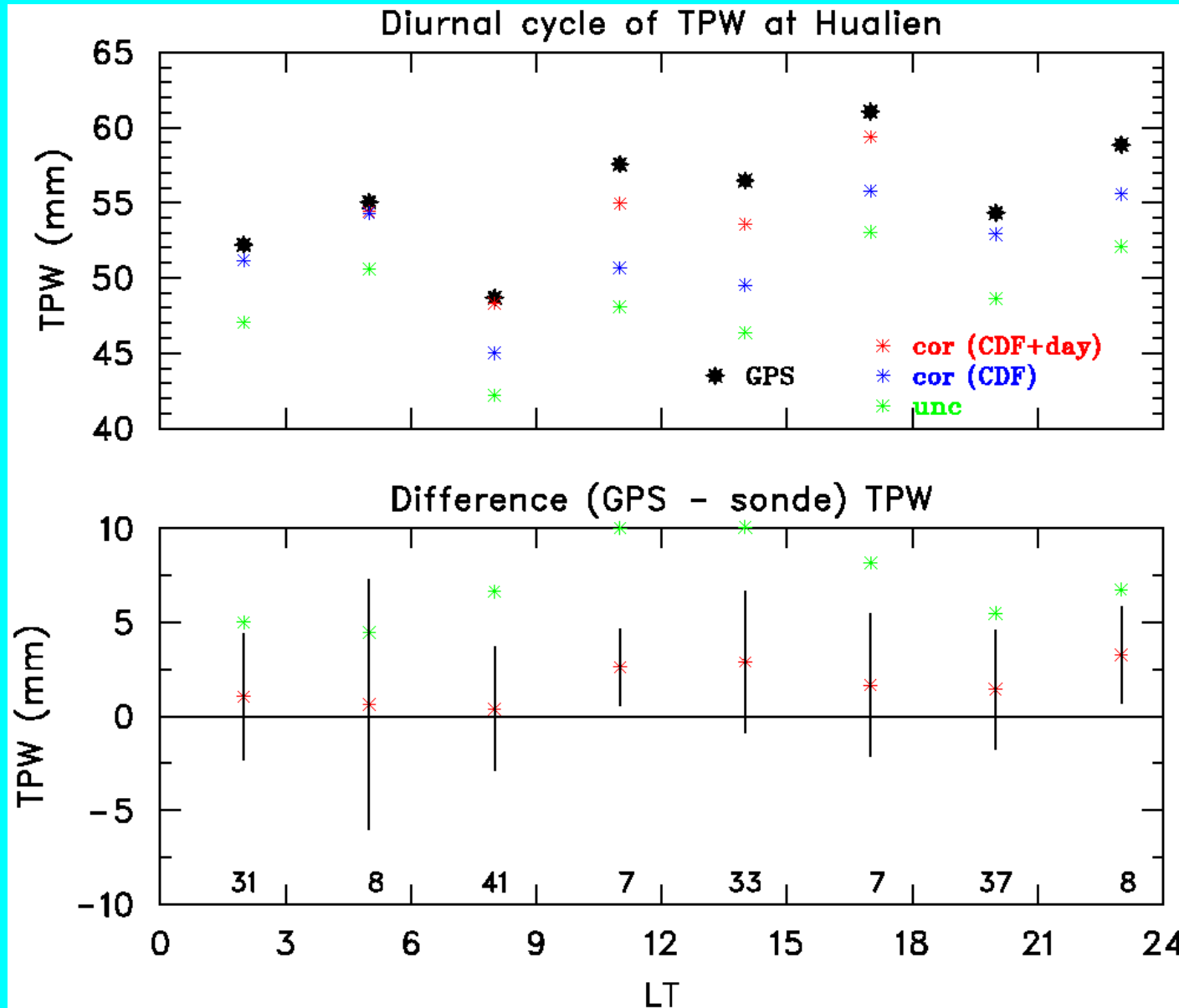

- $\overline{PW}_{GPS} - \overline{PW}_{sonde} = 2.6 \text{ mm}$
- PW differences at individual time of day reduced from 5-10 mm to 1-4 mm range.
- Largest differences during daytime hours.

Impact off humidity corrections on CAPE and CIN

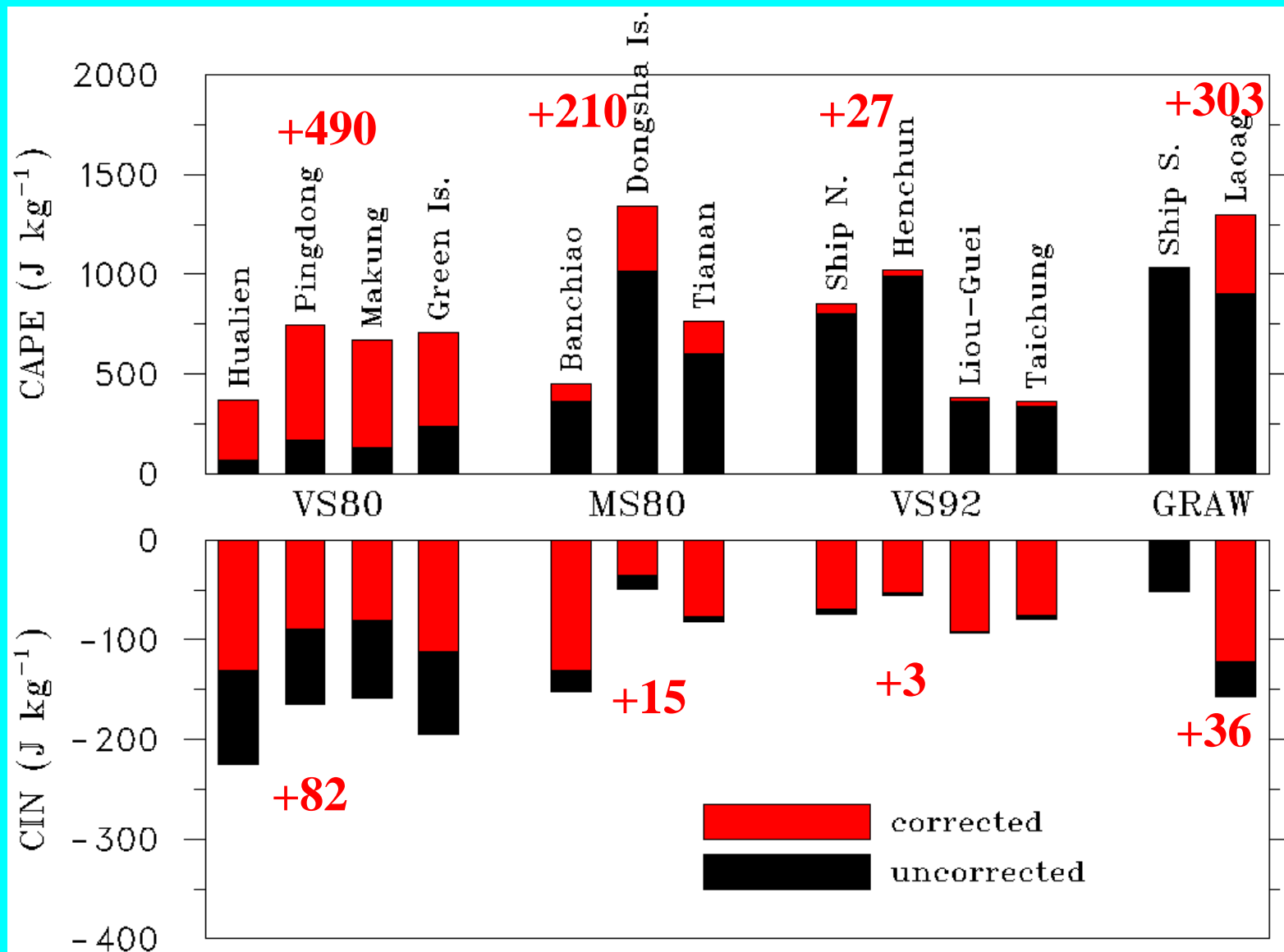

- Corrections results in huge increases in CAPE and CIN at VS80 sites (e.g. 4-fold increase in CAPE)
- These parameters at VS80 sites now comparable to nearby and VS92 sites.

Impact of correction on detrainment and cloud mass flux

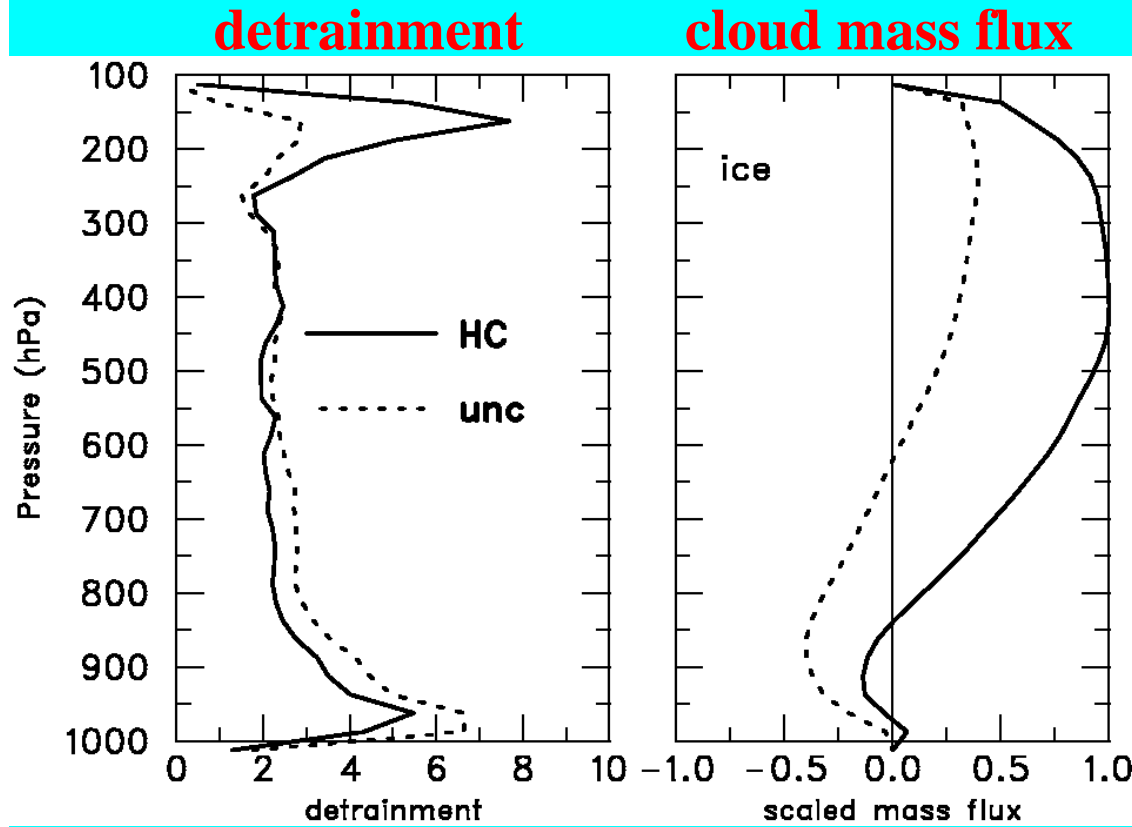

- Used Raymond-Blyth (1992) buoyancy sorting cloud model
- Results are for mean of **VS80 sondes**
- Left panel shows the probability that detrainment will occur at given level. It shows that with the correction less detrainment occurs below 400 hPa and more than 3x as much occurs above 200 hPa.
- This translates into a 72% increase in the cloud mass flux at mid-levels (right panel) in the HC sondes

type	mid-level mass flux increase due to HC	# sondes
VS80	+72%	836
VS92	+4%	315
MS80	18%	372
GRAW	+19%	??

Summary

- Large dry bias at VS80 sondes effectively corrected, except for Hualien which appears to still have a slight dry bias. These corrections will have a significant impact on how convection is simulated near these sites.
- Daytime dry bias corrected in VS92 sondes
- Slight dry bias in Meisei and GRAW sondes corrected with a less than optimal scheme.
- Both corrected and uncorrected versions will be available.
- Documentation of corrections should be completed within a month.
- A handful of volunteers are needed to review documentation and assess corrections before final corrected data (Levels 3 and 4) can be officially released.

Stages to developing a research-quality sonde dataset

High resolution sounding data (**Level 1**) is put into a common ASCII format and then run through the **ASPEN** (Atmospheric Sounding Processing Environment) software. ← **Level 2**



Perform a variety of QC (quality control) checks on data and compare data to independent measurements which allows us to identify problems (such as moisture biases). Using a variety of methods (e.g, intercomparison studies, statistical techniques, etc) correction algorithms are developed and applied. → **Level 3**



Create 5-hPa vertical resolution data set, apply some additional subjective QC checks to create QC flags for each data value. Visually inspect each sonde in a Skew-T format and subjectively adjust QC data flags as needed. Merge with GTS resolution China soundings. → **Level 4**

Example of poor quality low-level thermodynamic data at SW Ship

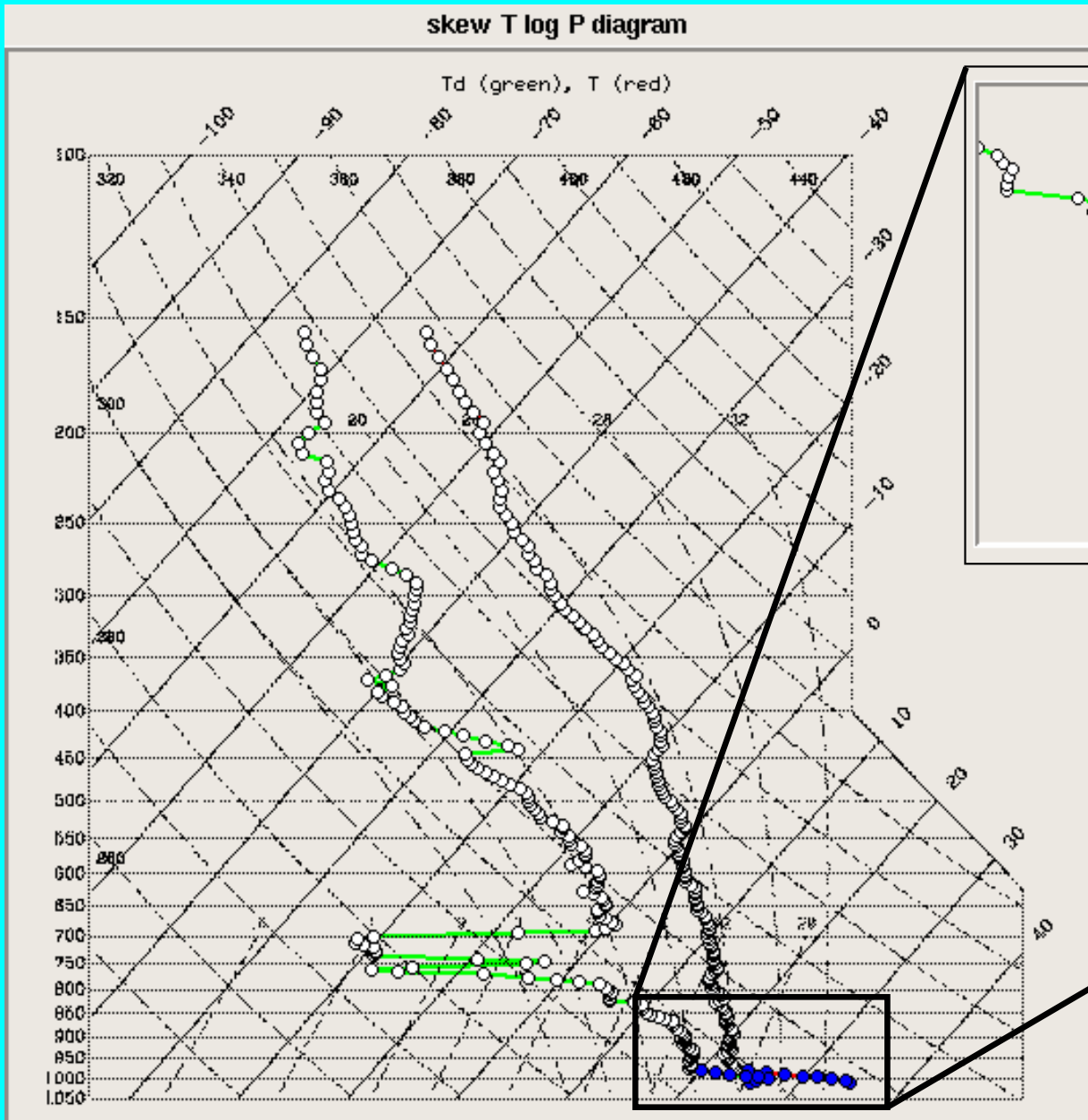

Occur most frequently in daytime sondes which suggest that it may be related to heating effects of ship structure.

Questions?



Picture taken from ASTER dropsonde flight on 30 May 2008, Cb penetrating through low-

Supplemental material

Recognizing these problems, a series of intercomparison sonde launches were conducted.

The idea here is to use the VS92 sonde as a reference sonde, since these sondes have been shown to have little or no RH bias for nighttime launches, and a well-documented daytime dry bias (related to solar heating effects) that can easily be removed.

With this in mind:

- Under the direction of Dr. Po-Hsiung Lin, **12 launches** were conducted at Banchio intercomparing the **VS92** sondes with **Meisei** and **GRAW** sondes. 4 launches were conducted in April 2008 and 8 additional launches in October 2008. (6 daytime and 6 nighttime launches). *Unfortunately these sondes were not representative of monsoon conditions and thus are **not** optimal for correcting TiMREX sondes.*
- Under the direction of Dr. Ching-Hwang Liu, **18 launches** were conducted at Pingdong intercomparing the **VS92** and **VS80** sondes for the period from 18 May to 9 June. The objective was to document the atmosphere as broadly as possible (day/night, wet/dry). They ended up with 10 daytime and 8 nighttime launches (6 rainy, 3 cloudy, and 9 fair).

Various stages of Banchiao intercomparison launch on 15 April 2008

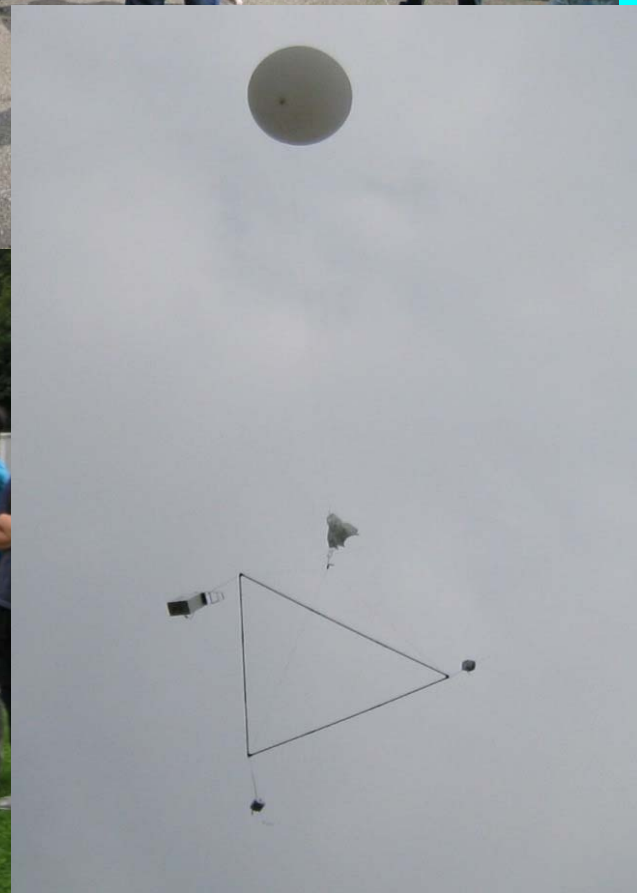
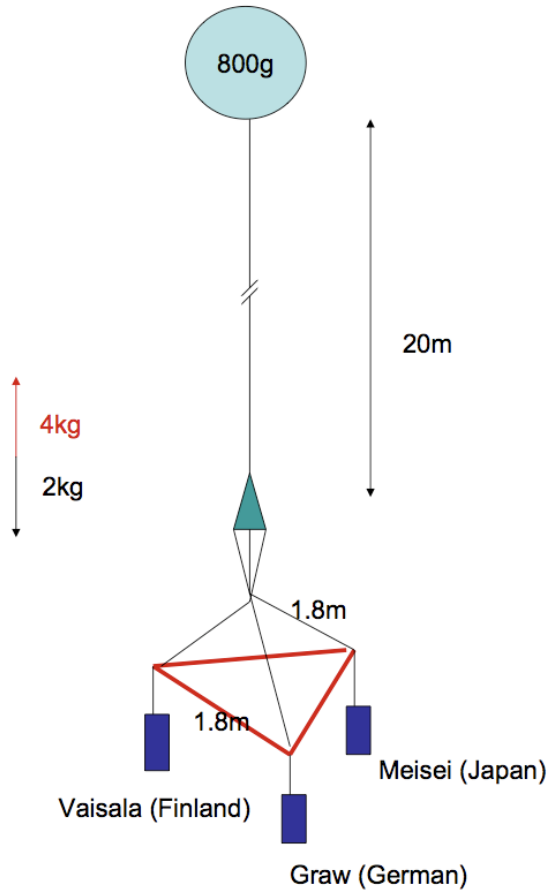

Differences in moisture and temperature fields

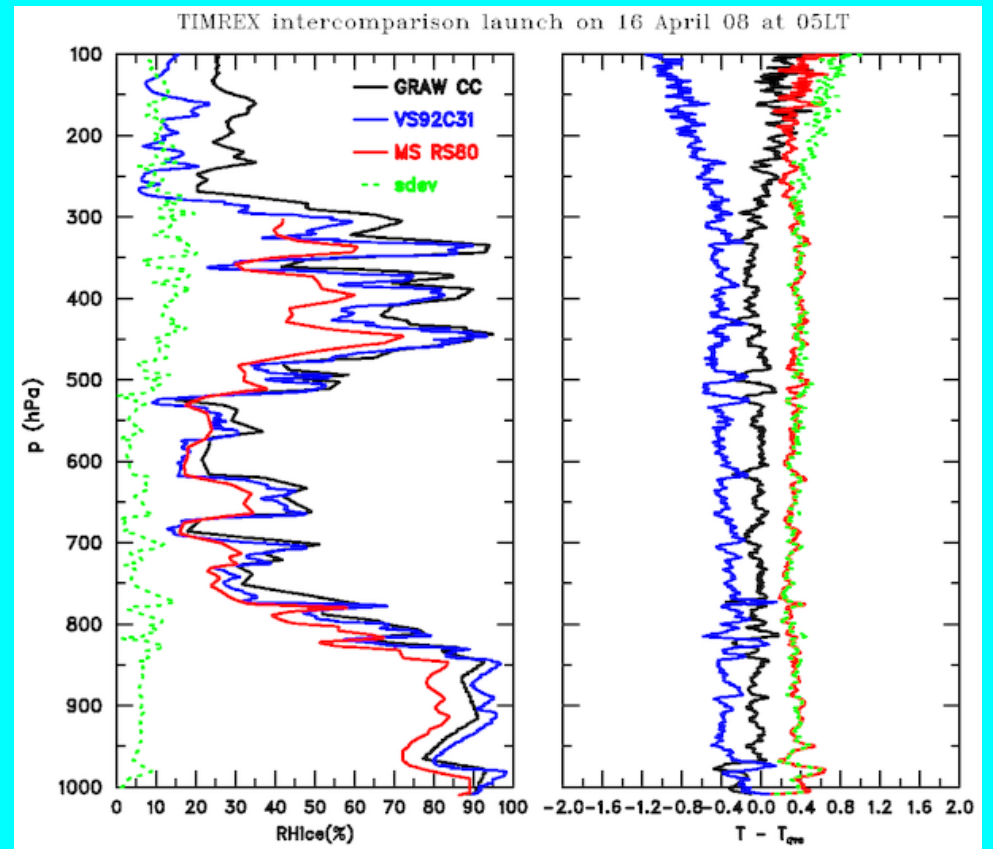
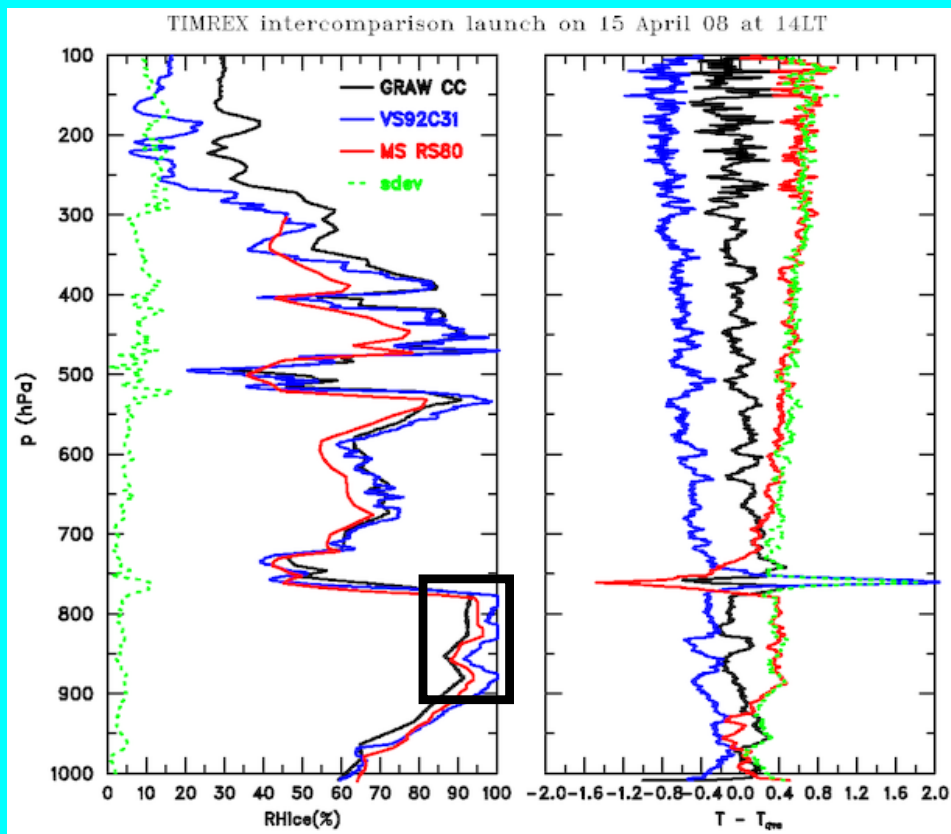

How are how these intercomparison datasets used to construct a correction algorithm?

- The approach taken here is referred to as Cumulative Distribution Function (**CDF**) **matching**, which attempts to adjust the statistics of questionable data to be similar to that of reliable data from a reference sonde (in this case data from a Vaisala RS92).
- used to correct humidity biases in sonde dataset from other field programs such as AMMA and NAME.
- This method corrects all sondes to the standard of the Vaisala RS92. A second, additional correction is needed to correct the daytime dry bias present in the Vaisala RS92.

CDF matching method at Pindong

- Application of the CDF matching method using the 18 intercomparison launches results in the RH correction tables.
- Shown below are correction tables for night (left) and daytime (right) sondes at Pingdong; nighttime correction is larger because the daytime Vaisala RS92 sondes contains a dry bias themselves.

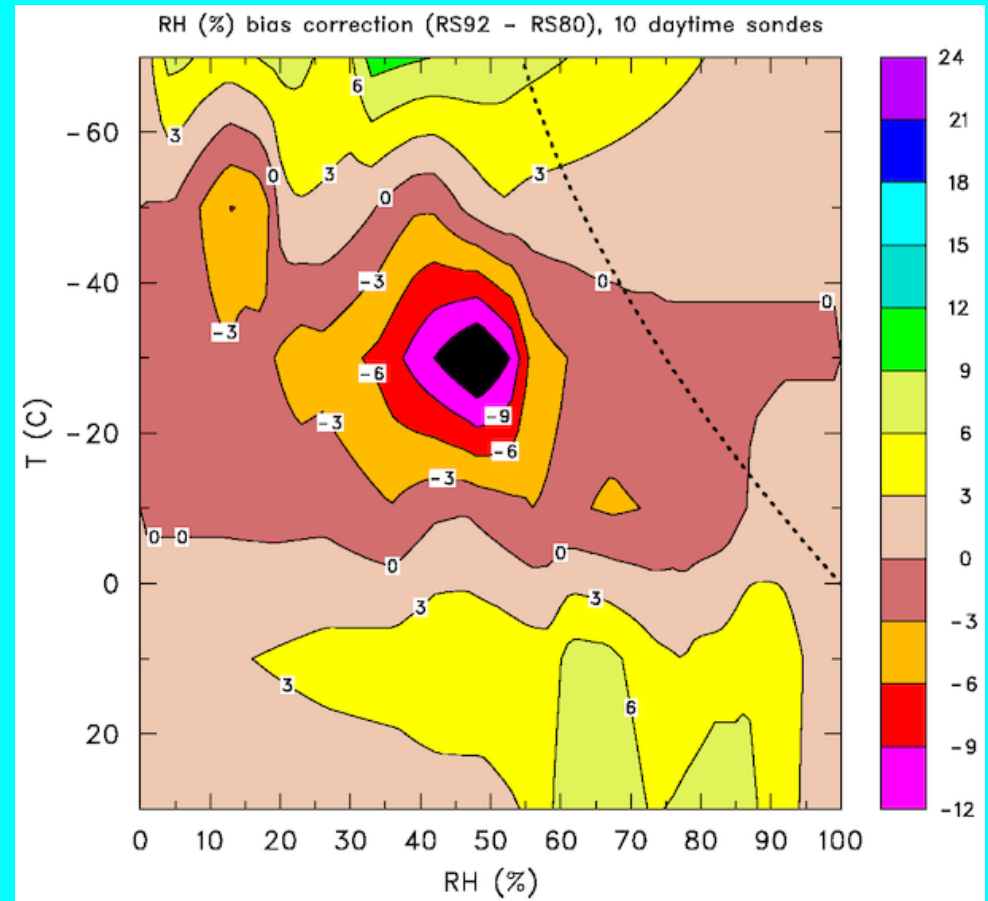
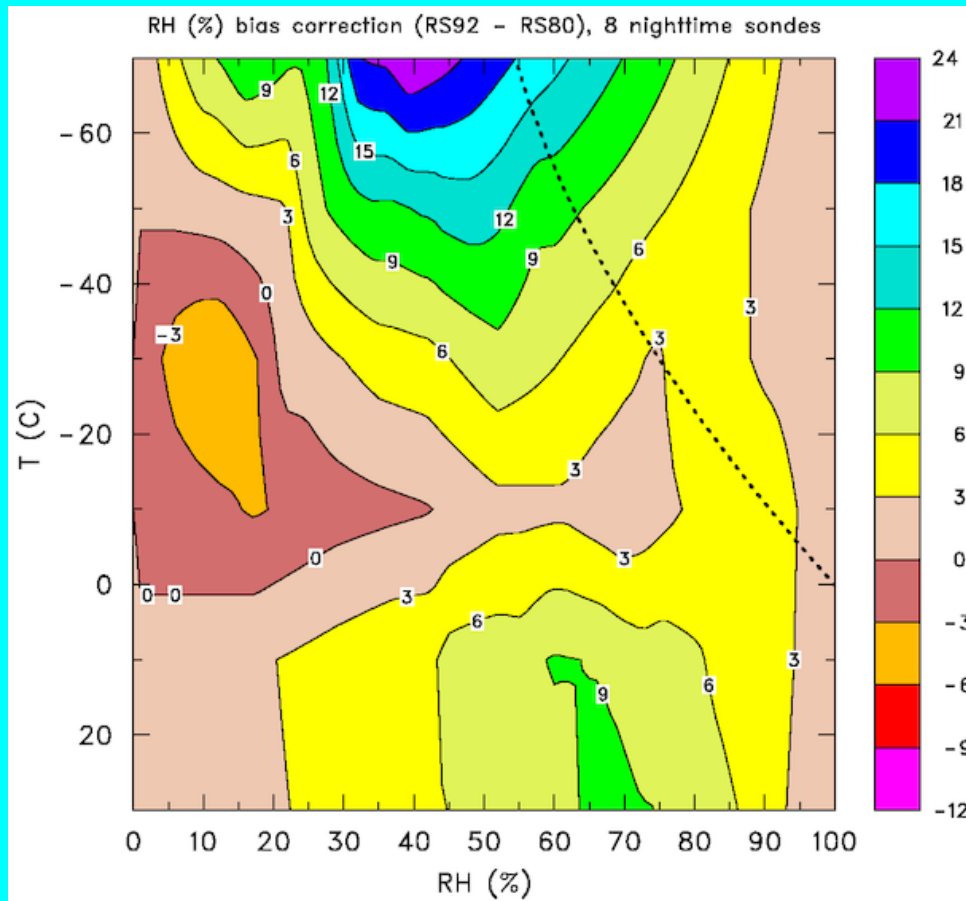

This correction table could potentially be used to correct RH at all four VS80 sites.

As an alternative to using the CDF matching method for correcting RH in the VS80 sondes:

- The Vaisala company took a sample of 70 VS80 sondes from the four sites using this sonde type for further investigation of the problem (*thanks to Dr. Lin, Po-Hisung*).
- They determined that the dry bias in sondes at three of the sites (Pingdong, Makung and Green Is) was indeed beyond what was typical and that its cause was an unusually high level of contaminants on the humidity sensors.
- These sondes were given a heat treatment to burn off the contaminants, then recalibrated resulting a set of corrected calibration coefficients.
- Using a statistical average correction for these 70 sondes, Vaisala provided corrected humidity coefficients for the VS80 sondes used during TiMREX
- Vaisala did not feel that the sondes used at Hualien were affected and thus no corrected coefficients were provided for this site.
- In the end the Vaisala Corrected Coefficients (VCC) were used at Pingdong, Makung and Green Is and CDF matching was used at Hualien.

Daytime solar heating correction

- Several recent papers have reported on the VS80 and VS92 daytime dry bias and have suggested a correction.
- One of the simpler corrections, **which is independent of height**, has been suggested by Cady-Pereira et al. 2008. This correction is a function of the Vaisala sonde type and solar zenith angle (SZA) as shown below:

$$SF = \alpha * \exp[-0.2*SZA], \alpha = 0.067 \text{ for VS80 (CP80), and } 0.093 \text{ for VS92 (CP92)}$$

- Note: VS80 sondes have smaller correction due to protective cap used on these sondes which reduces the effect of solar radiation.

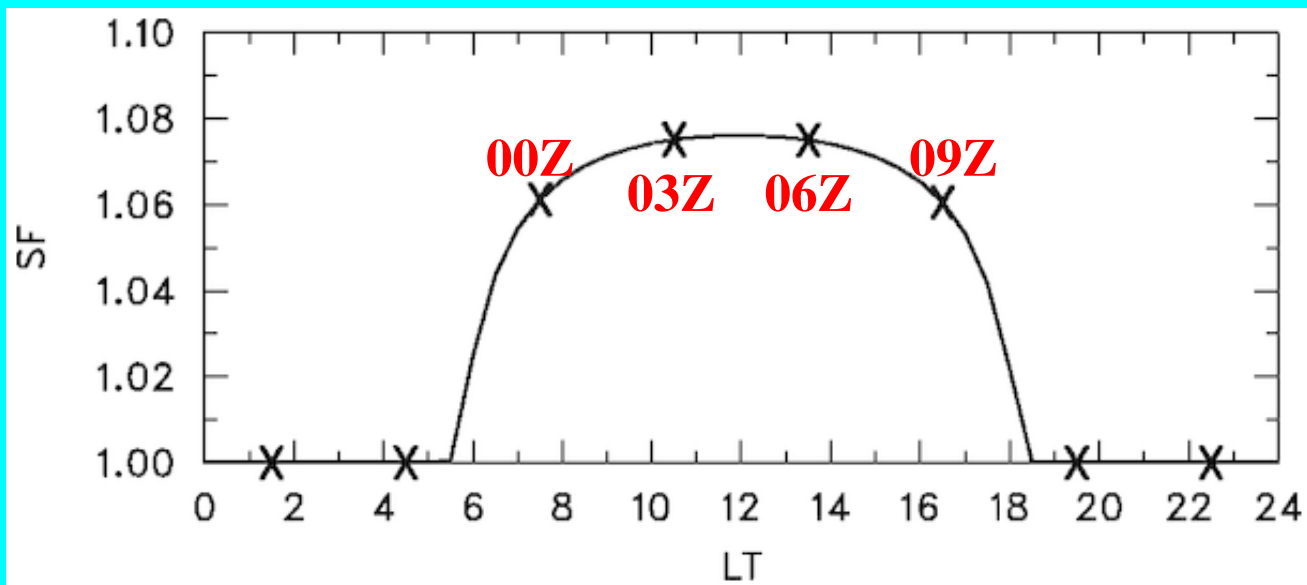

Scale Factor (SF) used to multiply specific humidity for correcting sondes for daytime dry bias. X's along curve - indicate sonde times at Pingdong.

- only CP correction is available for VS80 sondes
- several corrections have been proposed for VS92 sondes
- the most appropriate correction comes from Yoneyama's et al 2009 (YON) study based on sondes taken in an oceanic, convective environment.

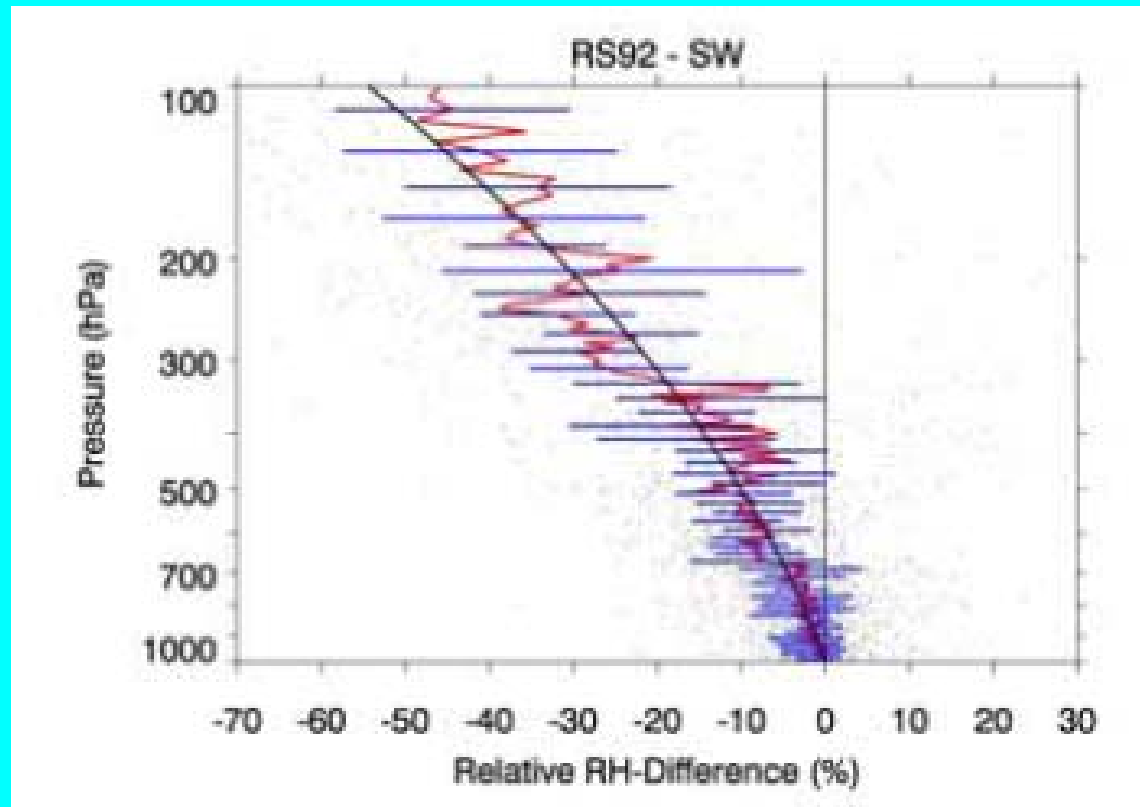

Smooth curve is polynomial fit to red line (VS92-SW RH difference based on 14 intercomparison launches)

- correction is function of solar zenith angle and height
- little correction near the surface but increases with height

Step 2: Identification of sonde biases \rightarrow development and application of correction algorithms

During the field experiment unusually large decreases in moisture were observed near the surface at the four sites using Vaisala RS80 sondes.

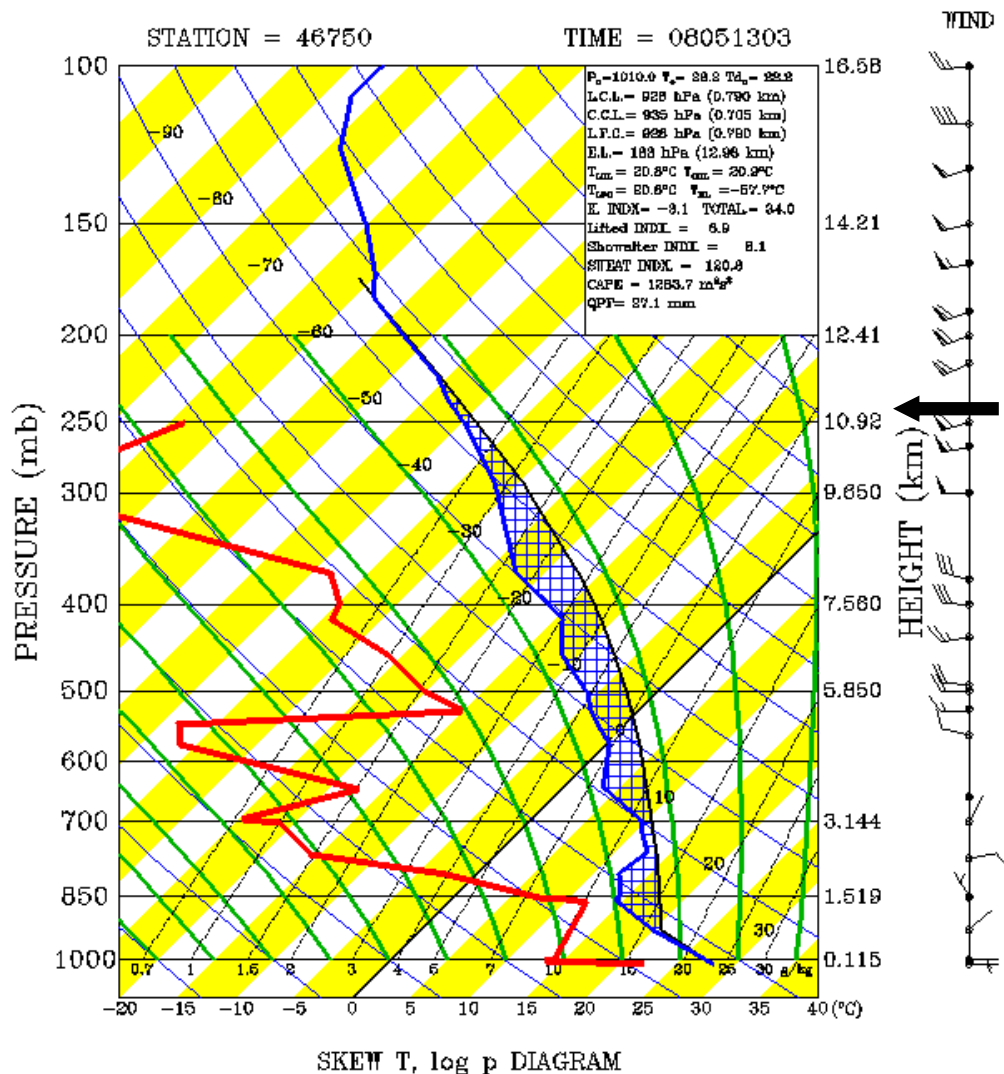

This example Skew-T plot from Pingdong on 13 May at 11LT shows a well-mixed temperature profile, but a 9°C drop in T_d from the surface to first sonde data point (where the surface value is an independent obs from the sonde). There were also clouds at the time yet the data indicated no saturation.

Example of CDF matching method

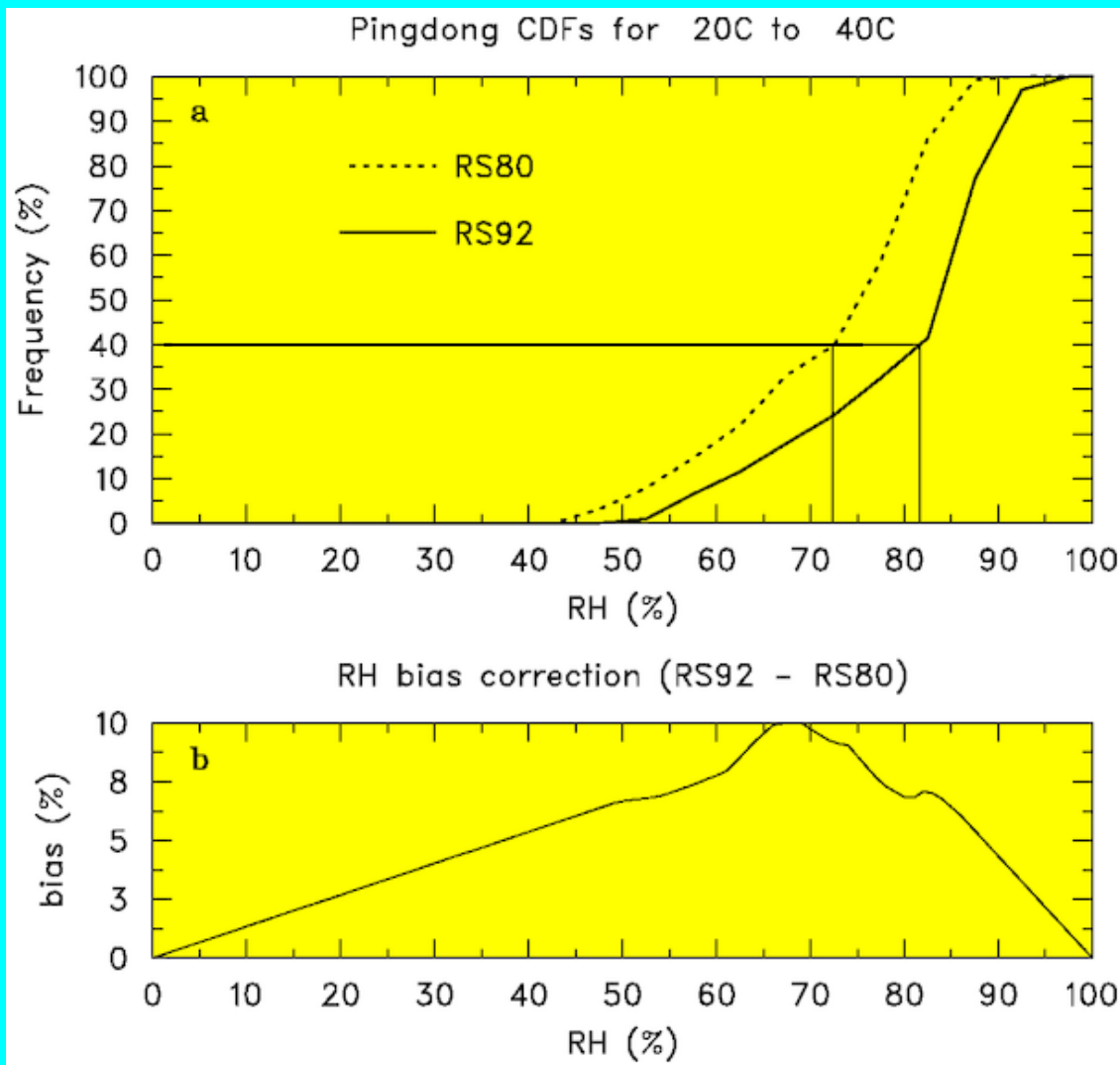

- Since the bias varies in the vertical, CDFs are computed for every 20°C temperature bin from +40°C to -80°C.
- CDFs for each sonde type are matched for each percentile and in each temperature interval as shown in top panel.
- In the example shown here the RS80 value of 72% at the 40% percentile is matched to the corresponding RS92 value of 81%, resulting in 9% bias correction for an RS80 data value of 72% (as shown in bottom panel).

Bias correction tables for GRAW sondes based on CDF matching of Vaisala RS92 and GRAW sondes at Banchiao

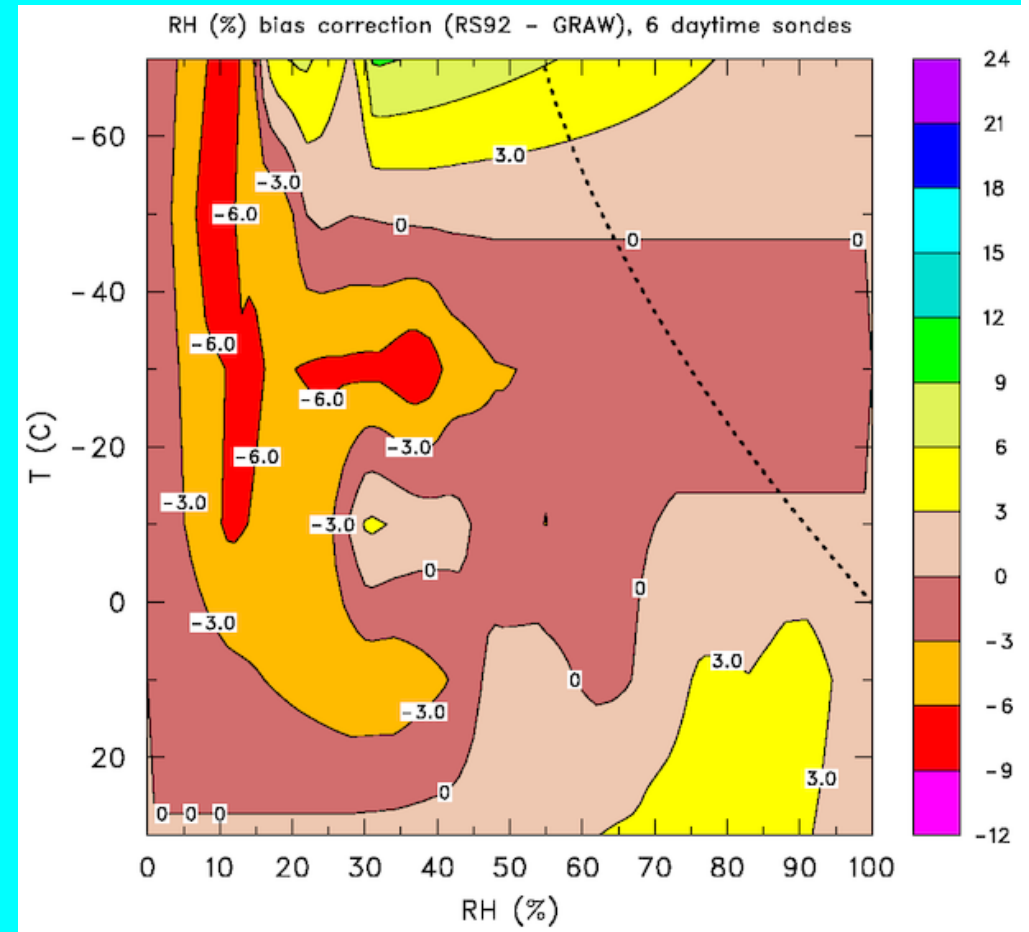
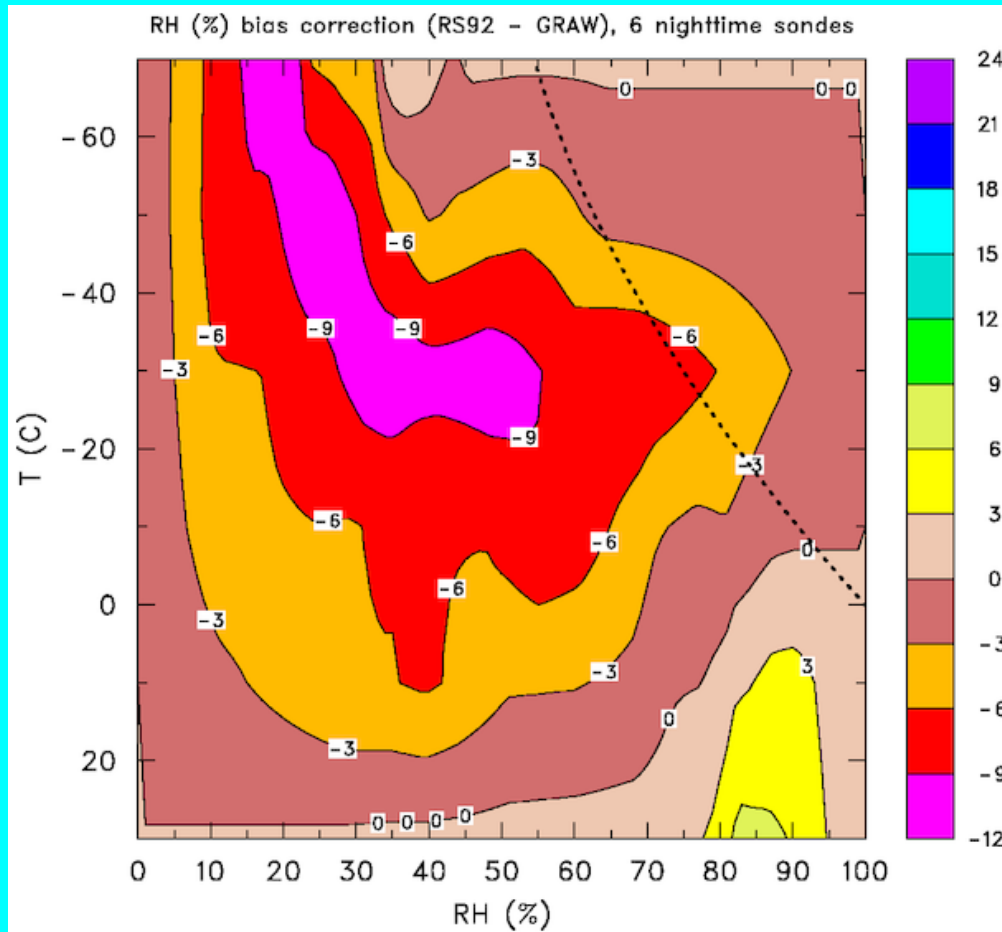

- These bias tables suggest a small dry bias (3-5%) exist in GRAW sondes at lowest levels. This dry bias appears smaller during day but this effect is related to the dry bias present in Vaisala RS92 daytime sondes.
- More analysis is needed to determine which sondes are responsible for the cold temperature biases (i.e., is there a moist bias in the GRAW sondes or a dry bias in the Vaisala sondes.)

Bias correction table for Meisei RS80 sondes based on CDF matching of Vaisala RS92 and Meisei sondes

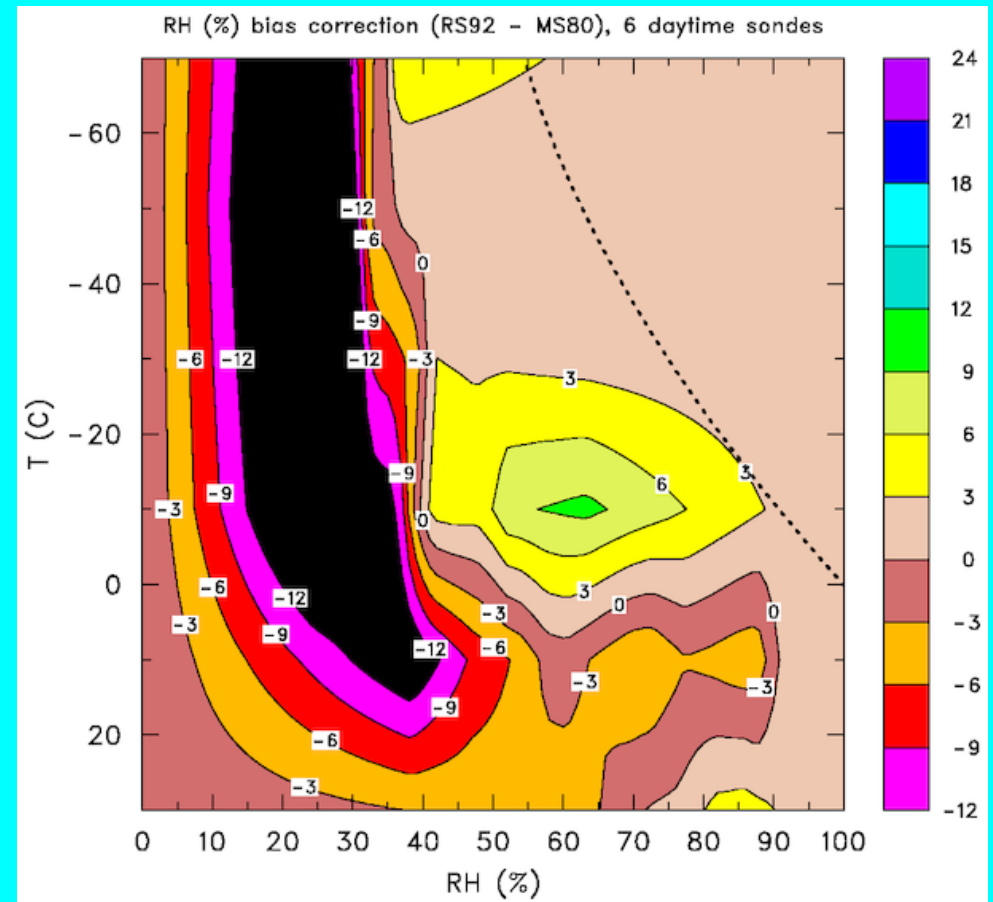
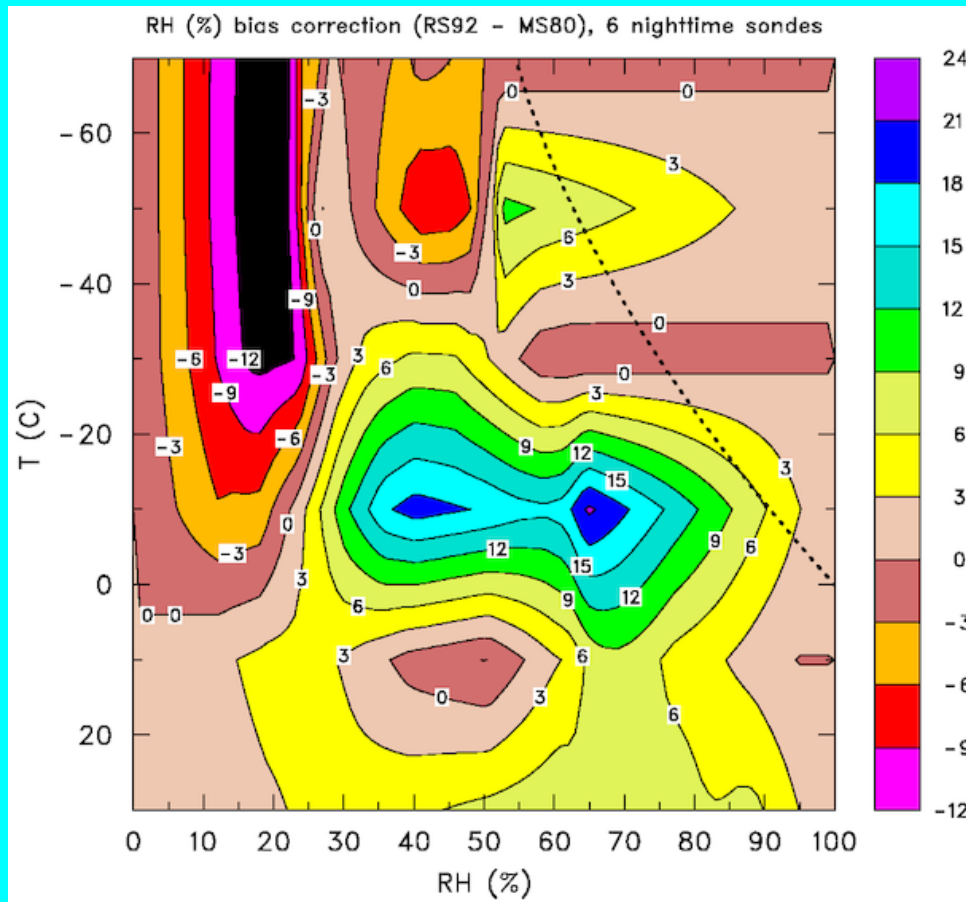

- Nighttime dry bias in Meisei sondes at low and mid-levels.
- Little dry bias in daytime Meisei sondes relative to Vaisala RS92.
- Large negative (moist) bias in Meisei sondes at low RHs is related to the insensitivity of the Meisei hygristor to measure very dry conditions.

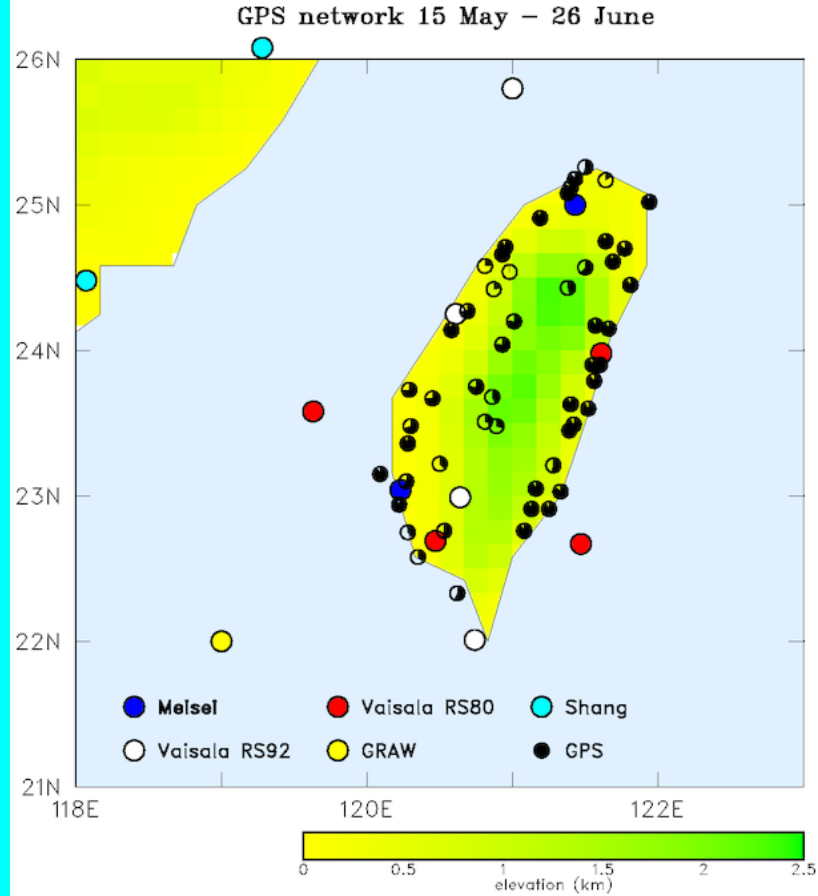

- The advantage of GPS PW is that it is available in all weather conditions, has high temporal resolution (5 min to 2 hrs), and is highly accurate (no systematic errors and an accuracy of 1-2 mm).
- Map shows the location of GPS and sounding sites in Taiwan.
- GPS PW data will be used to identify sonde humidity biases and evaluate the bias corrections.

• Another source of TPW is from microwave retrievals over the ocean from AMSR-E. In this region, the overpass times are at 02 and 14 LT and are available about 70% of the time.

• GPS and AMSR TPW are combined using an objective interpolation scheme to create a merged analysis from which we can estimate TPW at any point in the TiMREX domain.

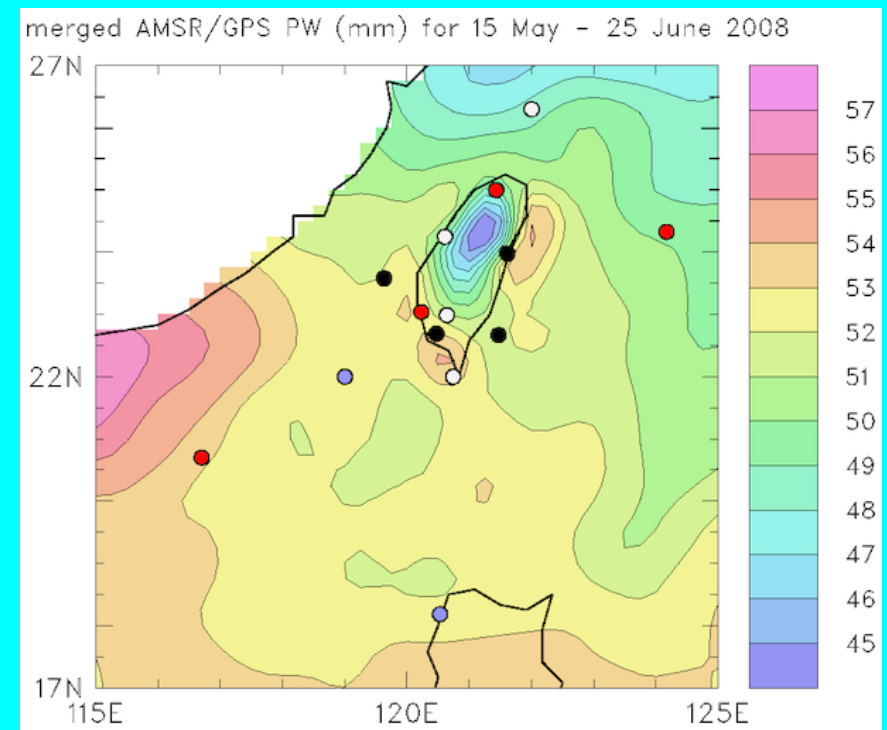

Impact of corrections at Pingdong

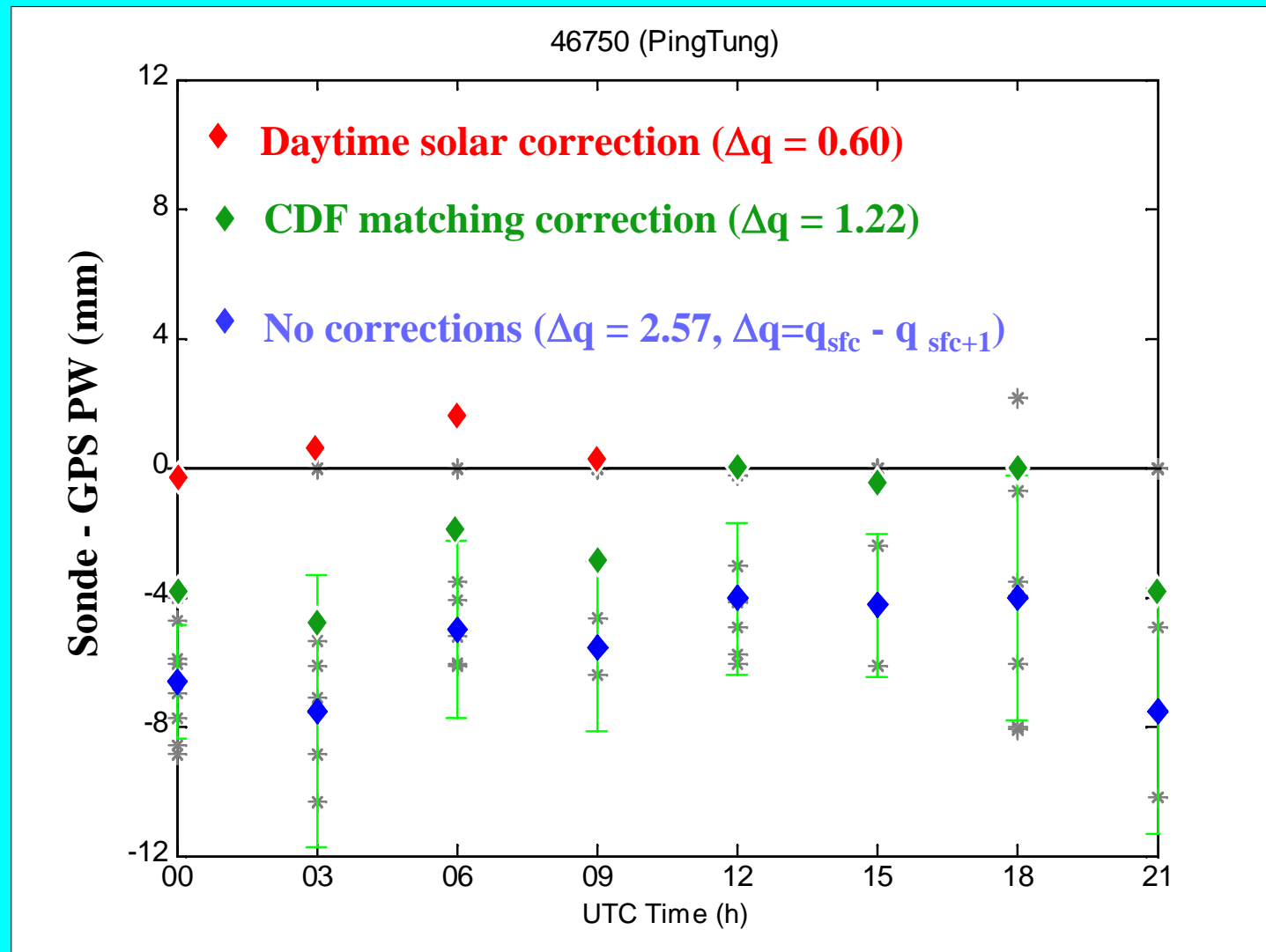

Corrections act to remove dry bias as evidenced by good agreement between corrected sonde and GPS PW values, and reduction in Δq to more reasonable values.

Diurnal Cycle of Sonde PW - GPS PW (mm)

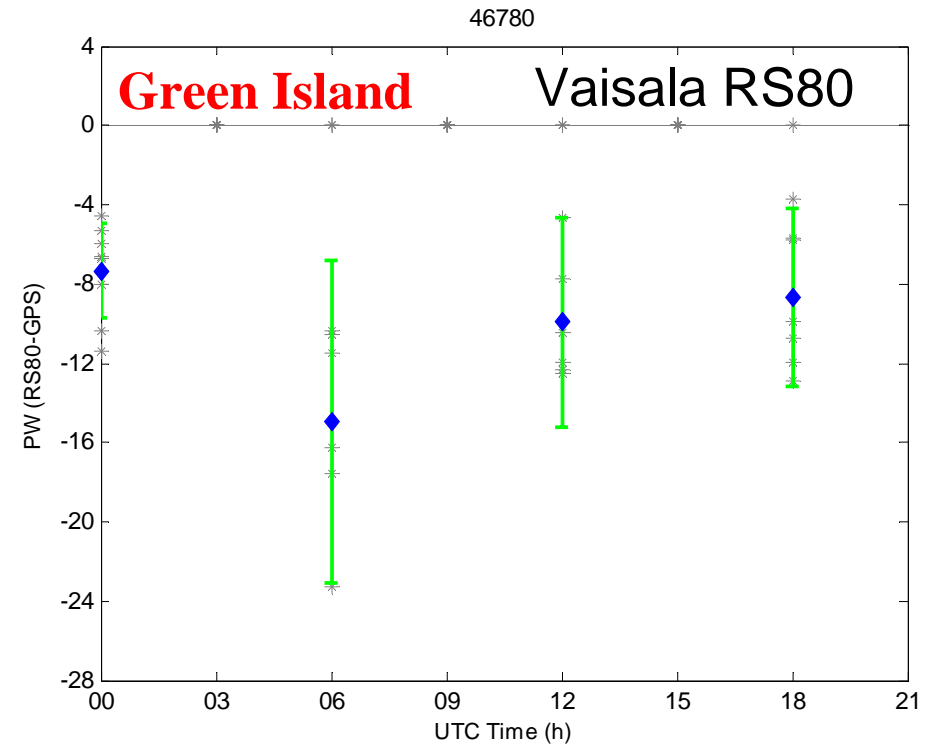
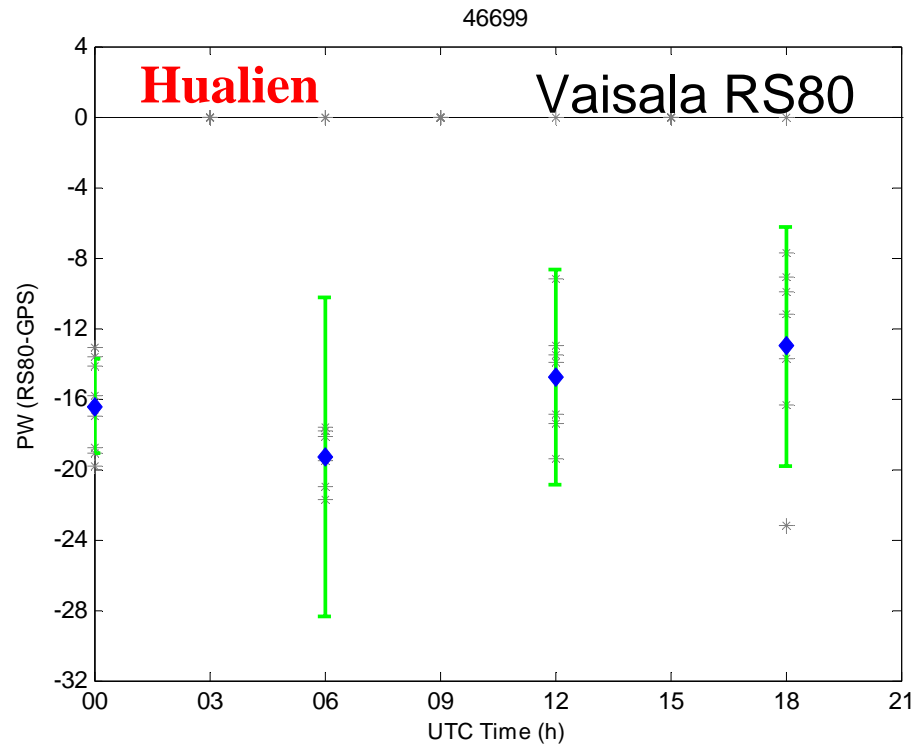

It still uncertain at this stage of the QC process if these large differences are real? These comparisons are based on the nearest GPS PW site. Weighting of all nearby sites will improve comparison as well as adjusting the GPS values to same elevation as the sonde site.

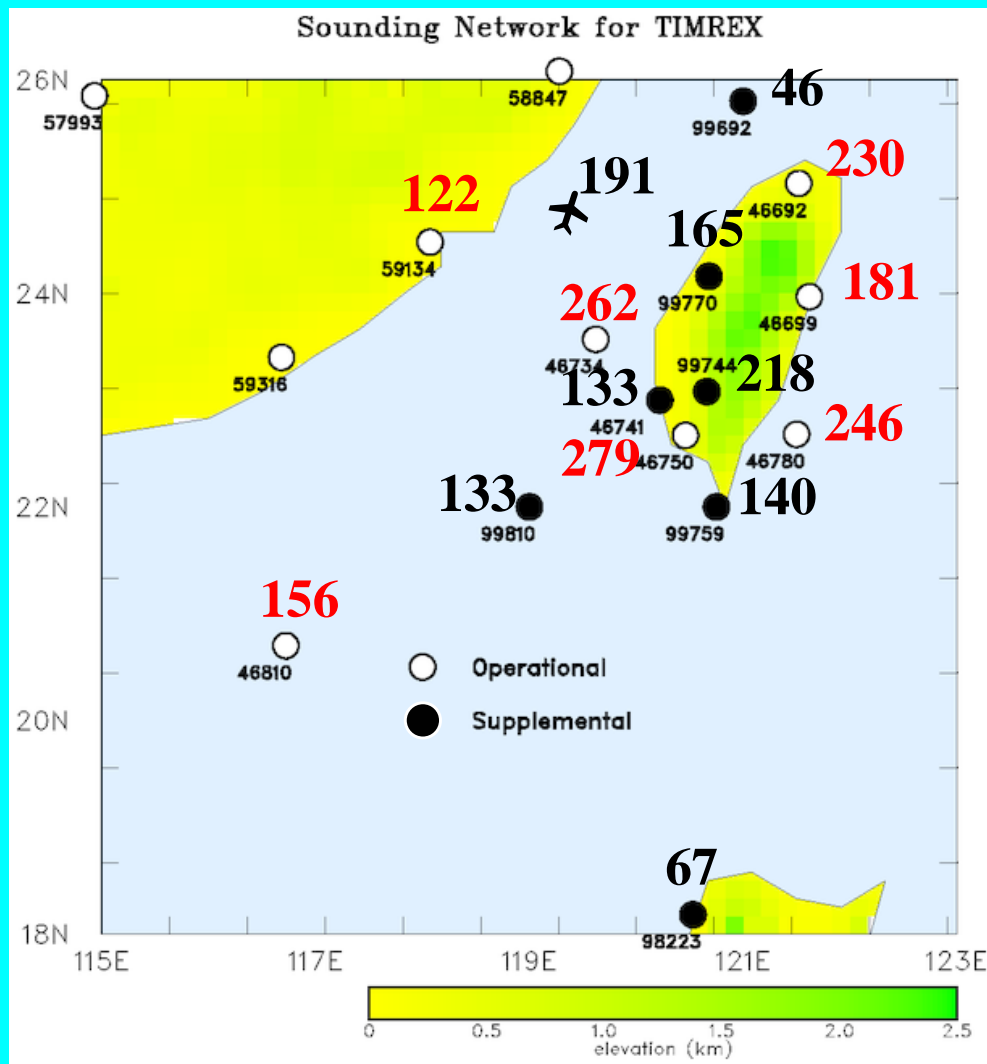

- Numbers show # of successful sonde observations made in the May-June 2008 period (white dots/red numbers indicate operational sites).
- In total 2447 sonde obs made (549 operational, 1898 supplemental). Of these 191 were dropsondes.
- During the SOP (15 May-26 June), 2283 sonde obs were made.

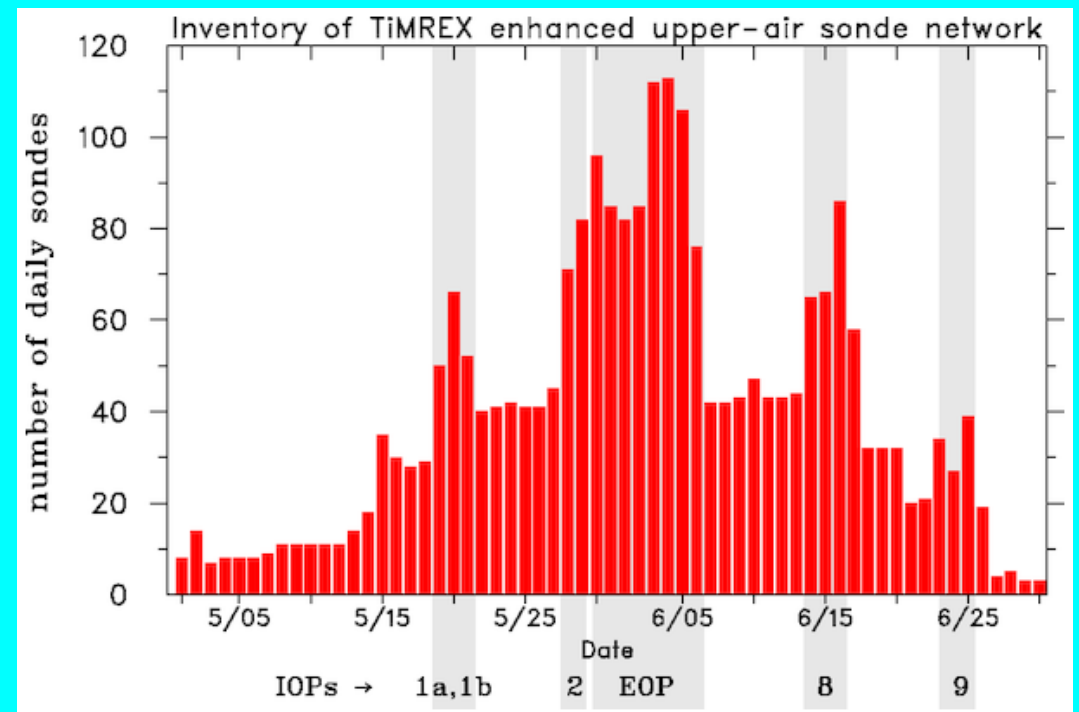

Time series of daily sonde # from 14 Taiwan sites

- During 8-day EOP (29 May-6 June), 755 sonde obs were made.
- This # may rival any field experiment for sonde frequency over area this size.

Pingdong sonde intercomparison (VS80, VS92) on 18 May 2008

From Dr. Ching-Hwang Liu (CCU)

Red:RS-92

Blue:RS-80

Summary:

1. T: very good agreement
2. RH: RS-80 is drier, as great as 9% RH
3. Wind direction: very good agreement
4. Wind speed: RS-80 is much weaker!

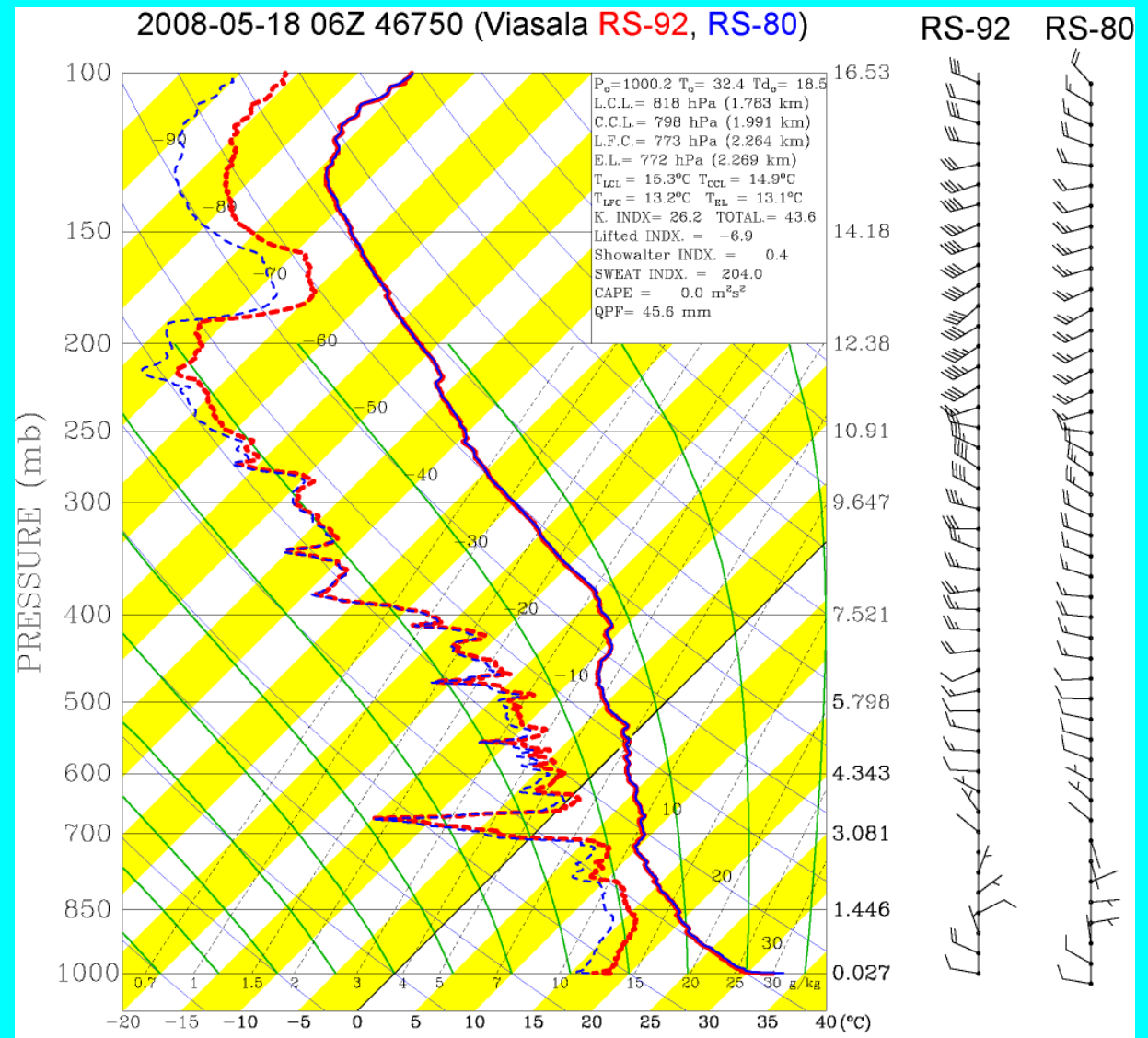

18 additional intercomparison launches were conducted at this site by Dr Liu to provide a basis for correcting the VS80 data.

Sonde intercomparison study conducted at Banciao weather station on 15-16 April 2008 under the direction of Dr. Po-Hsiung Lin. Study compared Vaisala 92, Meisei and GRAW sondes; Vaisala 80 systems were not portable and thus were not included in study.

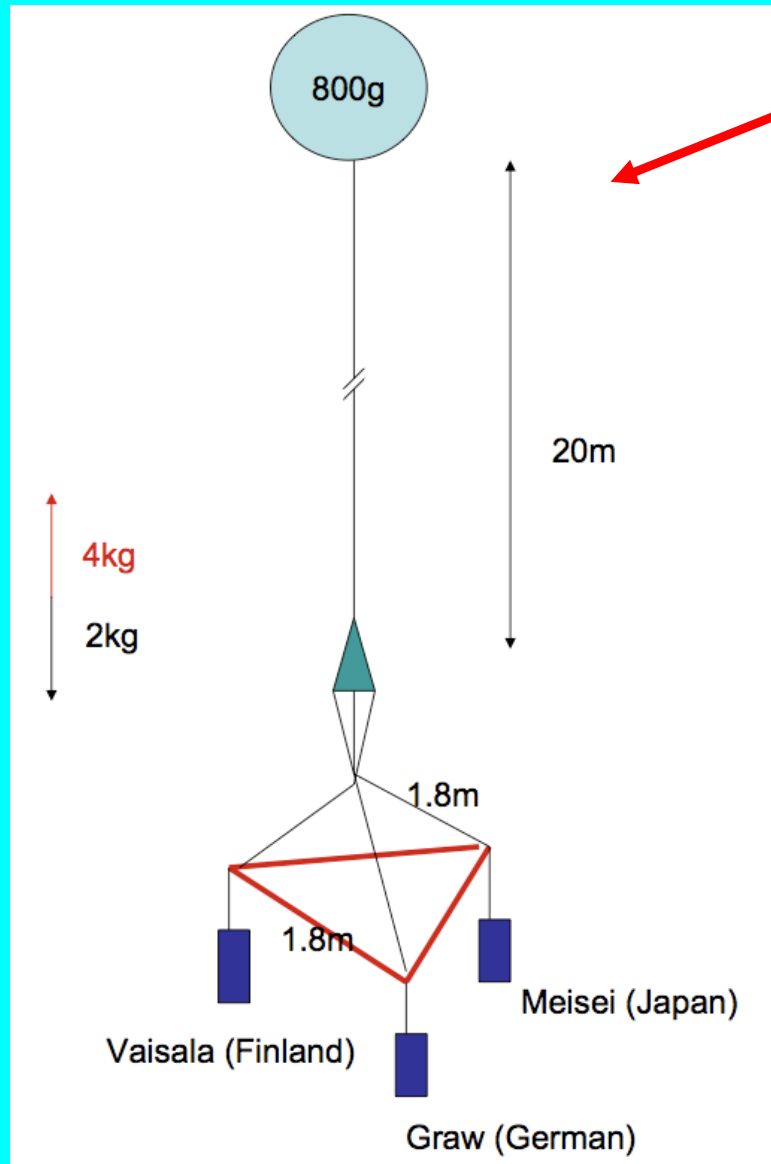

Launch set-up

Picture from
04/15 afternoon
launch

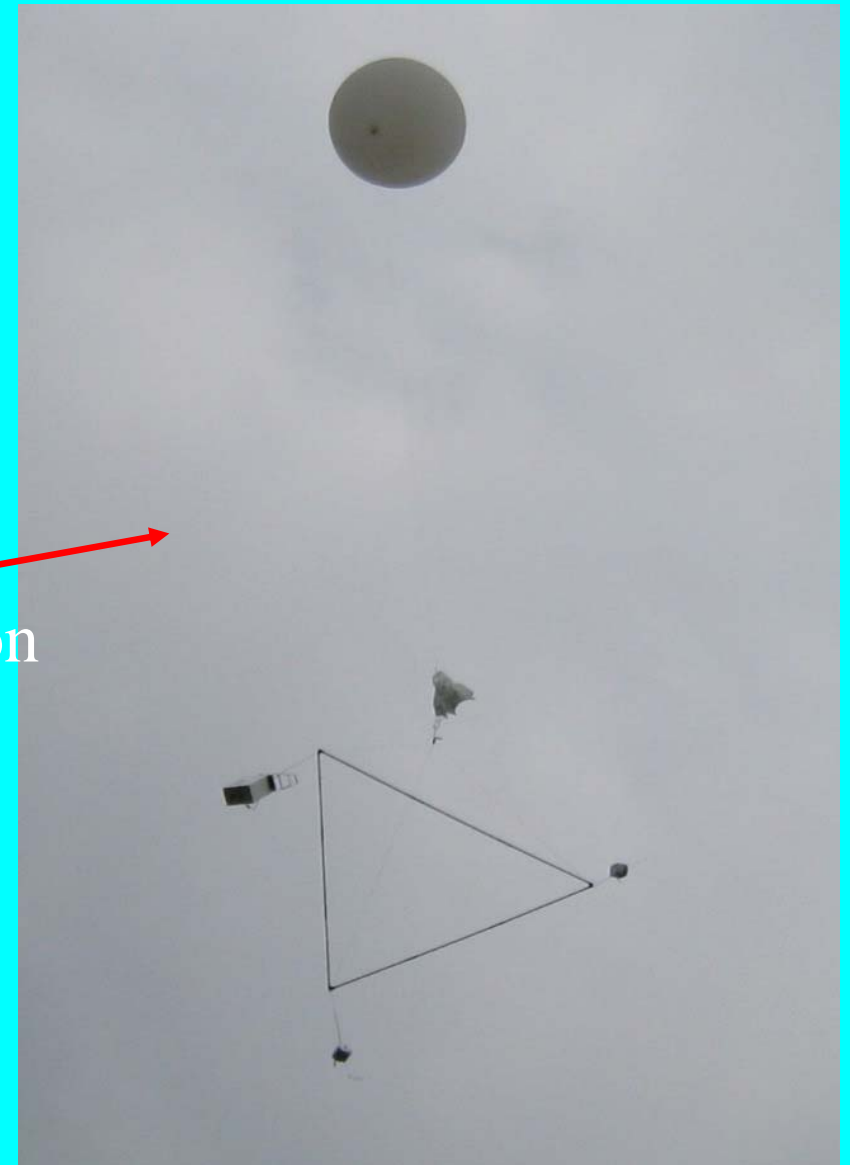

Summary of Banchiao intercomparison launches

Date/Time	Vaisala RS92	GRAW	Meisei RS80 tracking	Meisei RS92 GPS
04/14 21Z	x	x	Missing data below 400 hPa	
04/15 06Z	x	x	x	
04/15 21Z	x	x	x	
04/16 06Z	x	x	x	
10/04, 06Z	x	x	x	x
10/04, 12Z	x	x	x	
10/05, 06Z	x	x	x	x
10/05, 12Z	x	x	x	
10/11, 06Z	x	x	x	x
10/11, 12Z	x	x	x	x
10/12, 06Z	x	x	x	x
10/12, 12Z	x	x	x	x

Daytime launches shown in red

Differences in moisture and temperature fields

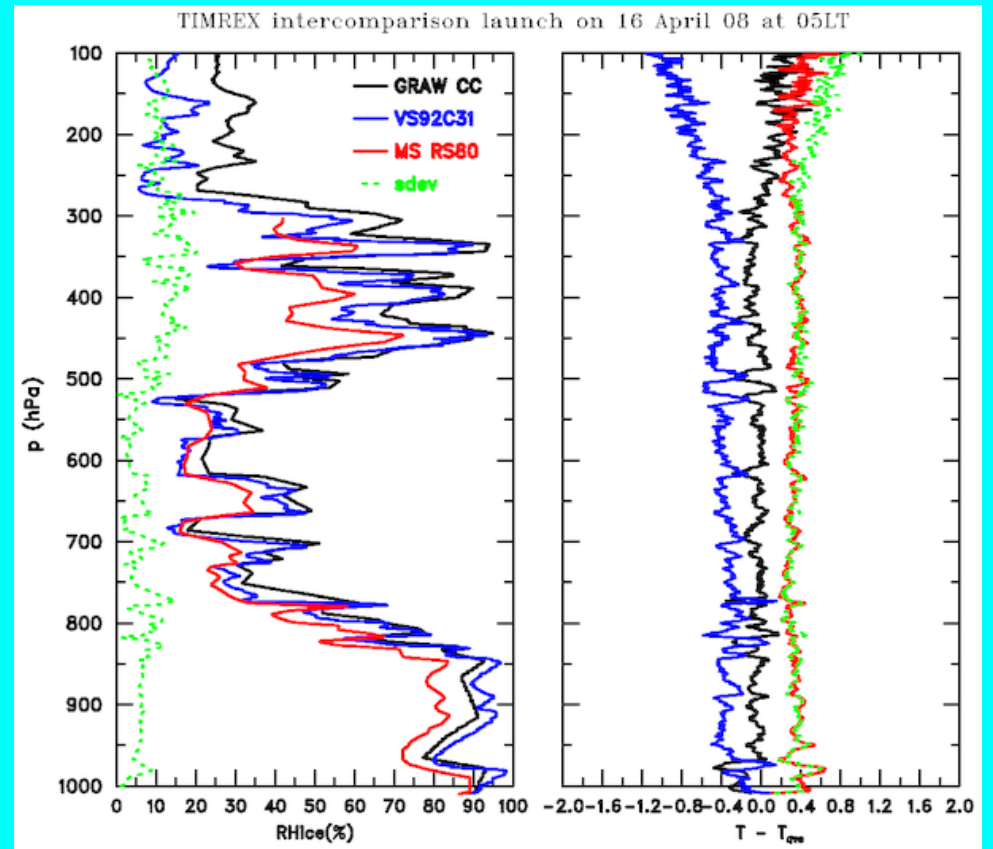
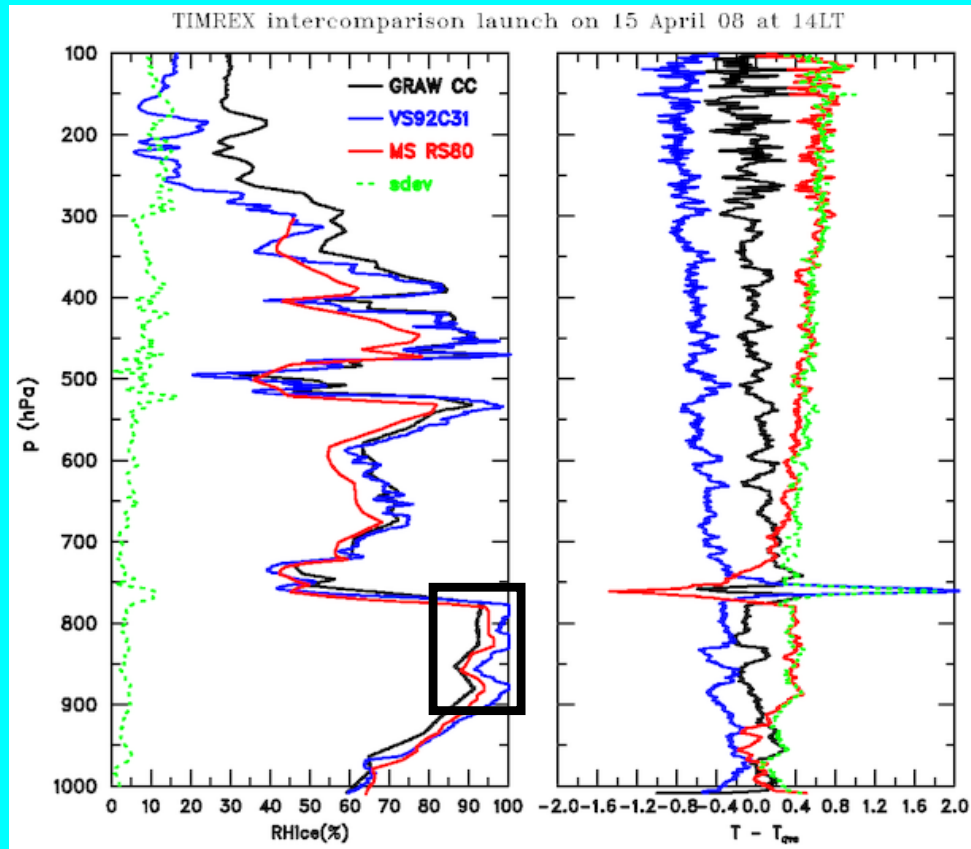

RH(%)	GRAW	VS92	MS
100-250	31.0	14.1	--
250-400	58.5	46.8	48.9
400-550	72.7	70.3	60.1
550-700	68.1	69.1	61.2
700-850	75.4	76.4	73.1
850-1000	78.1	83.5	81.8

RH(%)	GRAW	VS92	MS
100-250	28.1	13.3	--
250-400	61.6	46.8	46.2
400-550	57.4	51.6	40.1
550-700	31.6	26.3	23.3
700-850	56.1	51.8	43.1
850-1000	87.3	90.5	79.6

Skew-T plots for 2 launches from Banciao sonde intercomparison

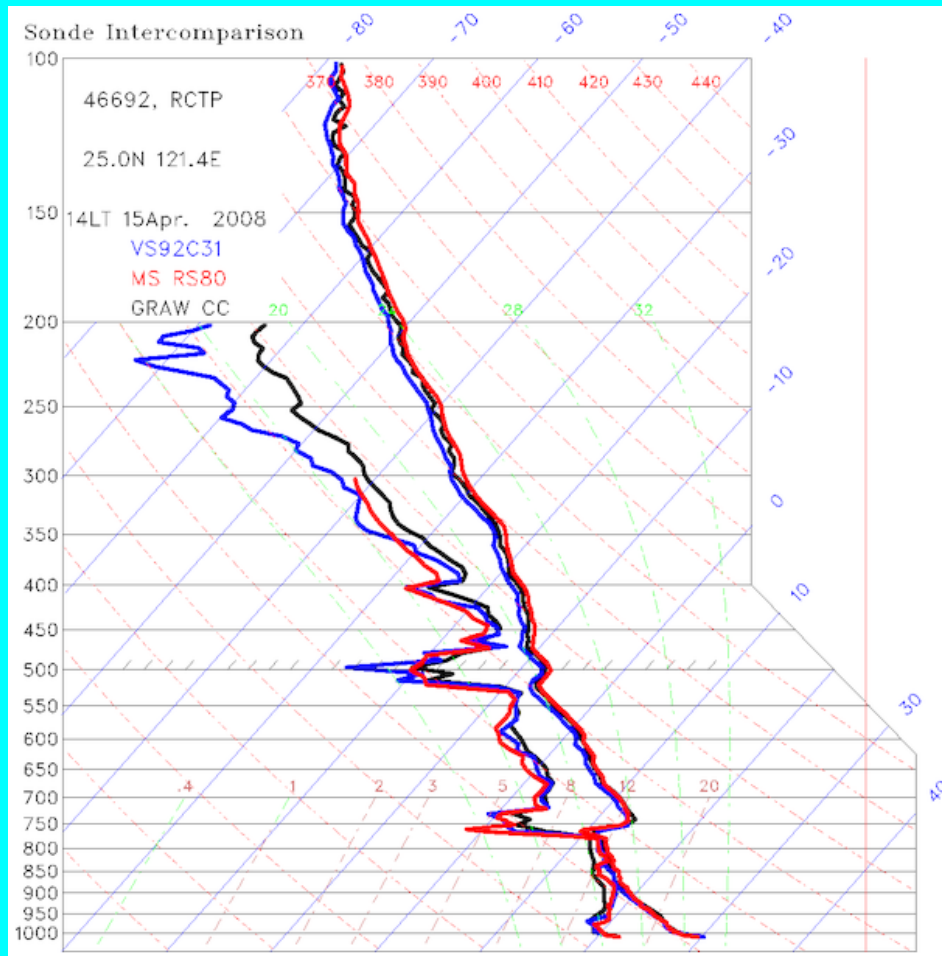

2pm on April 15

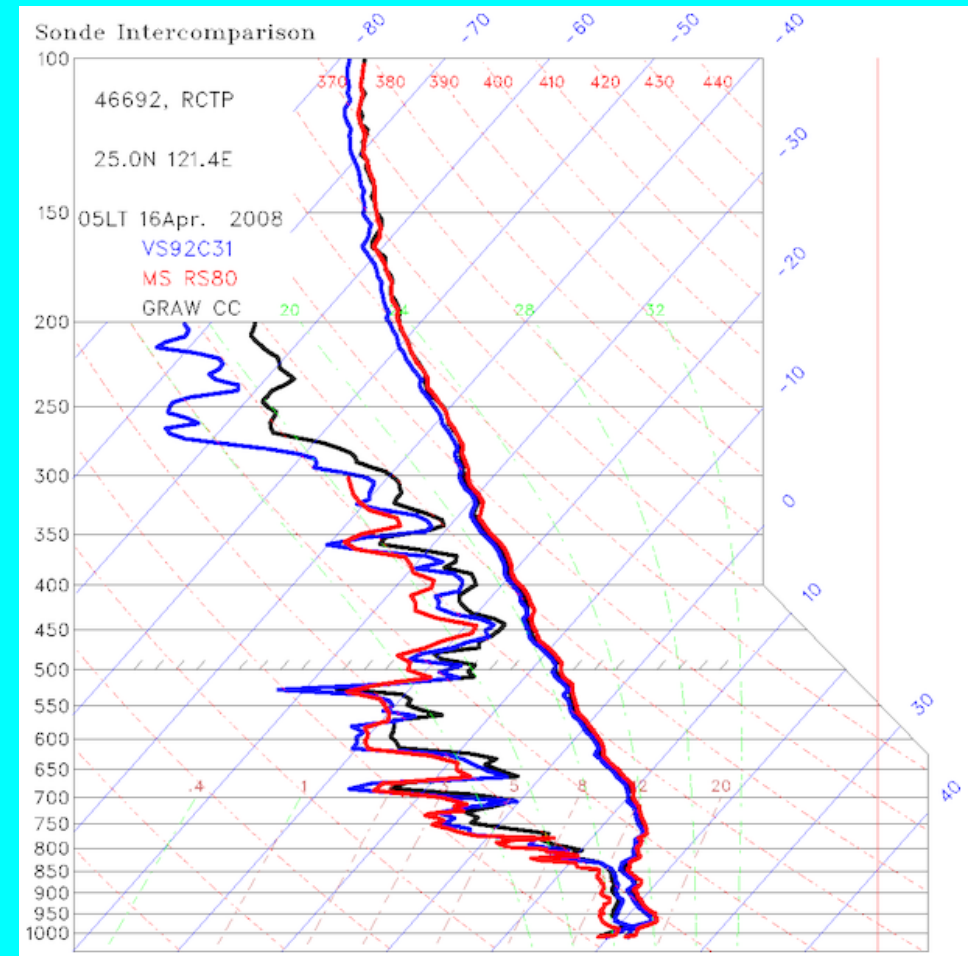

5 am on April 16

Winds essentially identical from each system, small differences seen in temperature and more significant differences in moisture profiles.

Preliminary results from April 2008 sonde intercomparison study

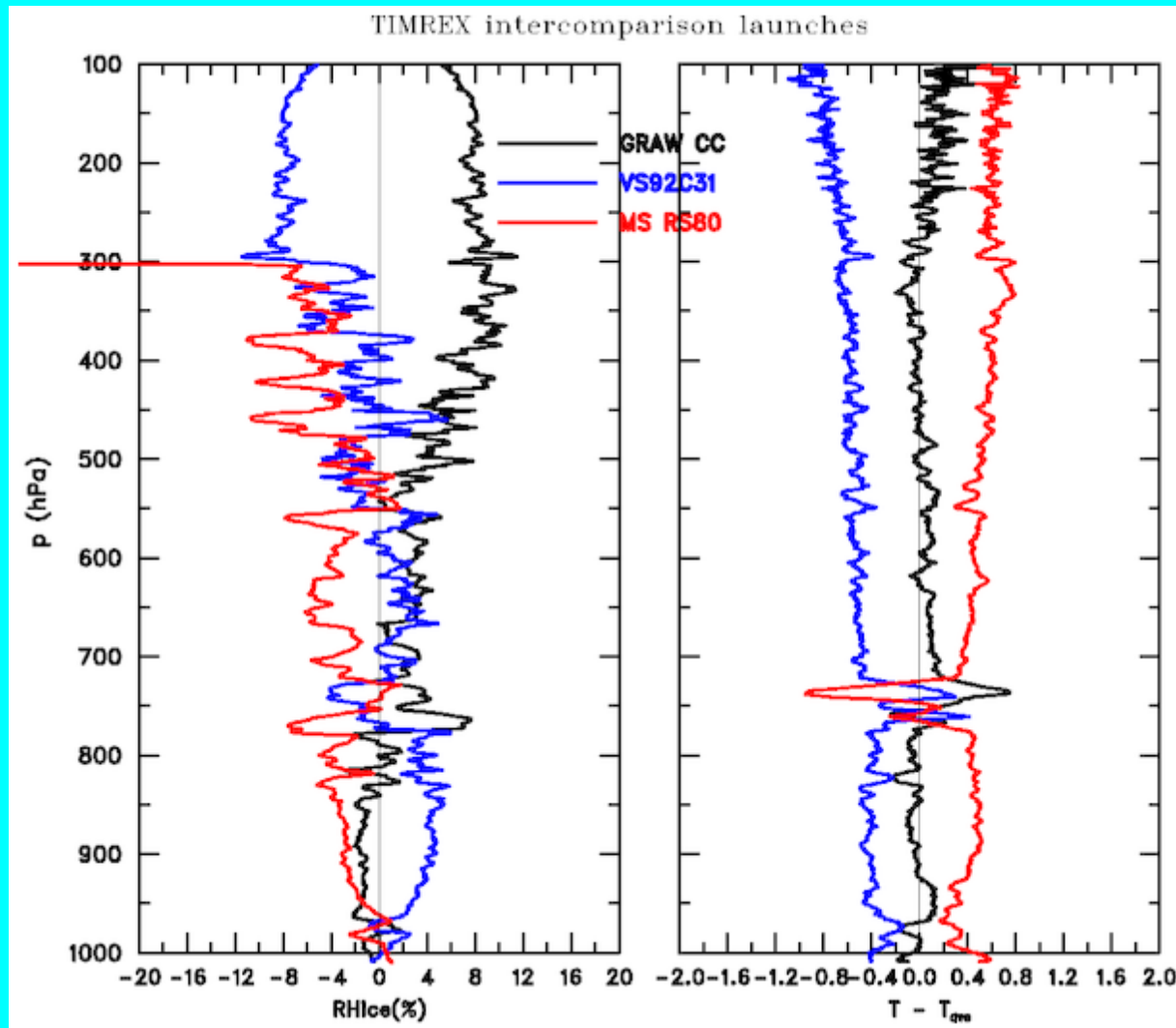

- Plots based on 3 launches, 1st launch had trouble with Meisei system
- Fields (RH to left, T to right) represent deviation from mean
- Vaisala 92 only one to reach saturation when encountering clouds.
- Graw and Meisei appears to have 3-5% dry bias from 800 to 950 hPa, Vaisala dry above 300 hPa
- Graw and Meisei have slight warm bias relative to VS92

Additional intercomparisons (6-12) are needed to establish a statistically robust correction.

SUMMARY

- ~95% success rate for launching upper-air sondes
- Significant dry biases exists in VS80 sondes at Air Force and Hualien
- Small biases observed in other systems (Meisei, GRAW, Vaisala 92)
- Intercomparison studies should be useful in correcting these biases
- Satellite and GPS precipitable water estimates will be used to validate humidity corrections.
- Algorithms could potentially be developed to correct operational sonde data which are ingested into NWP models.

Pingdong sounding for 13 May 2008 showing large T_d jump from surface point to first sonde point.

Two issues:

1. Location and quality of surface observation
2. Dry bias of Vaisala RS80A sondes

Fix:

1. Collocate reliable sfc obs with sonde
2. Record sonde serial # (gives us sonde age)
3. Intercomparison launches in a variety of wx conditions to establish a robust bias correction.
4. Use GPS-PW data to validate correction

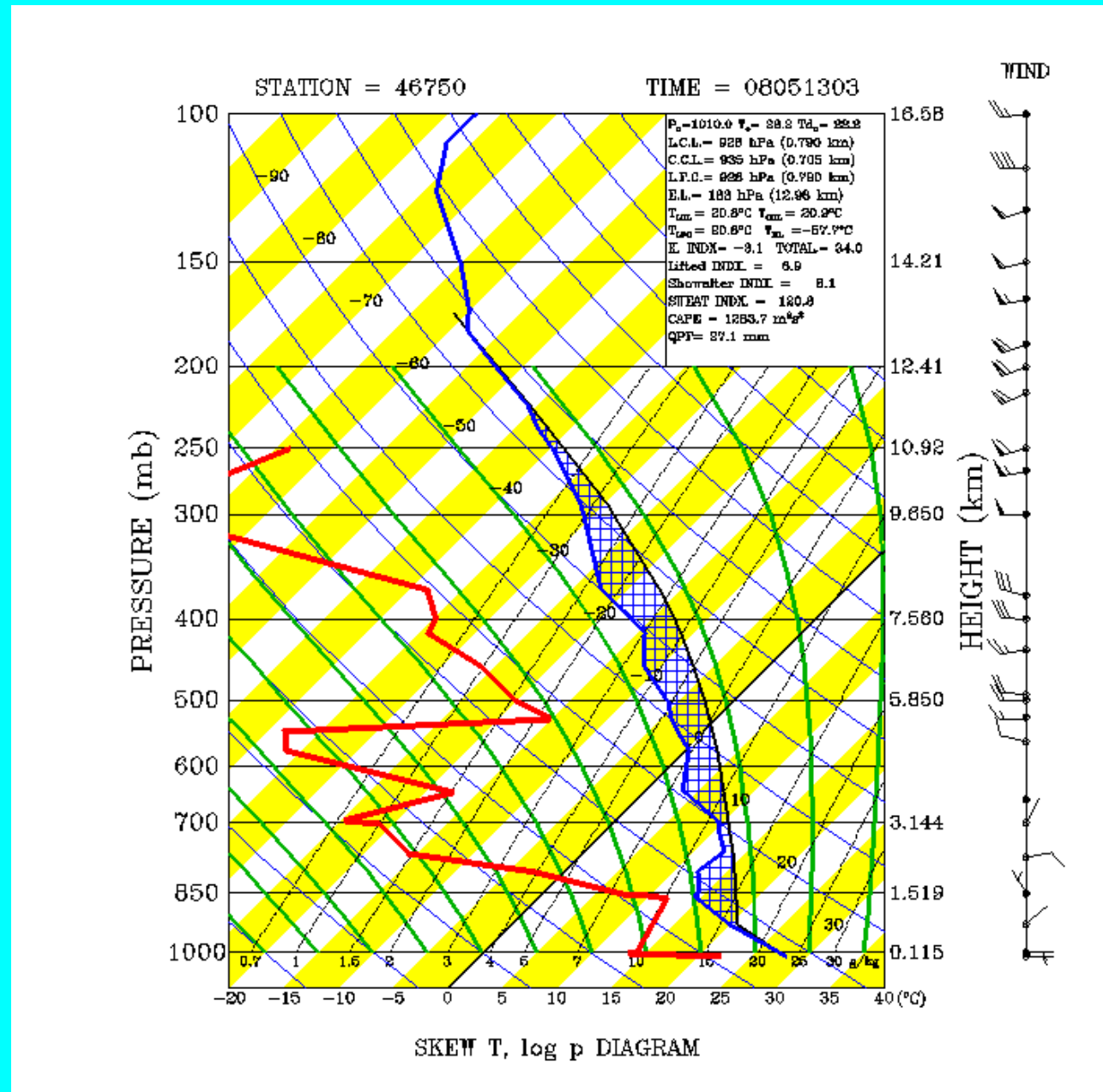

Dongsha intercomparison (VS92 and Meisei) on 06 May 3pm

From Dr. Ching_Hwang Liu (CCU)

Wind: Vaisala RS-92

Vaisala T:Blue, Td:Red

Meisei T:Sky blue, Td:Brown

Relative Humidity

p(mb)	mean RH(V)	mean RH(M)	mean RH(V-M)
100- 200	20.67	35.20	-14.53
200- 300	43.94	33.59	10.34
300- 400	28.13	32.70	-4.57
400- 500	44.29	40.11	4.18
500- 600	55.21	48.58	6.64
600- 700	65.87	58.90	6.97
700- 800	68.88	63.19	5.68
800- 900	68.16	64.78	3.38
900-1000	79.13	75.41	3.72

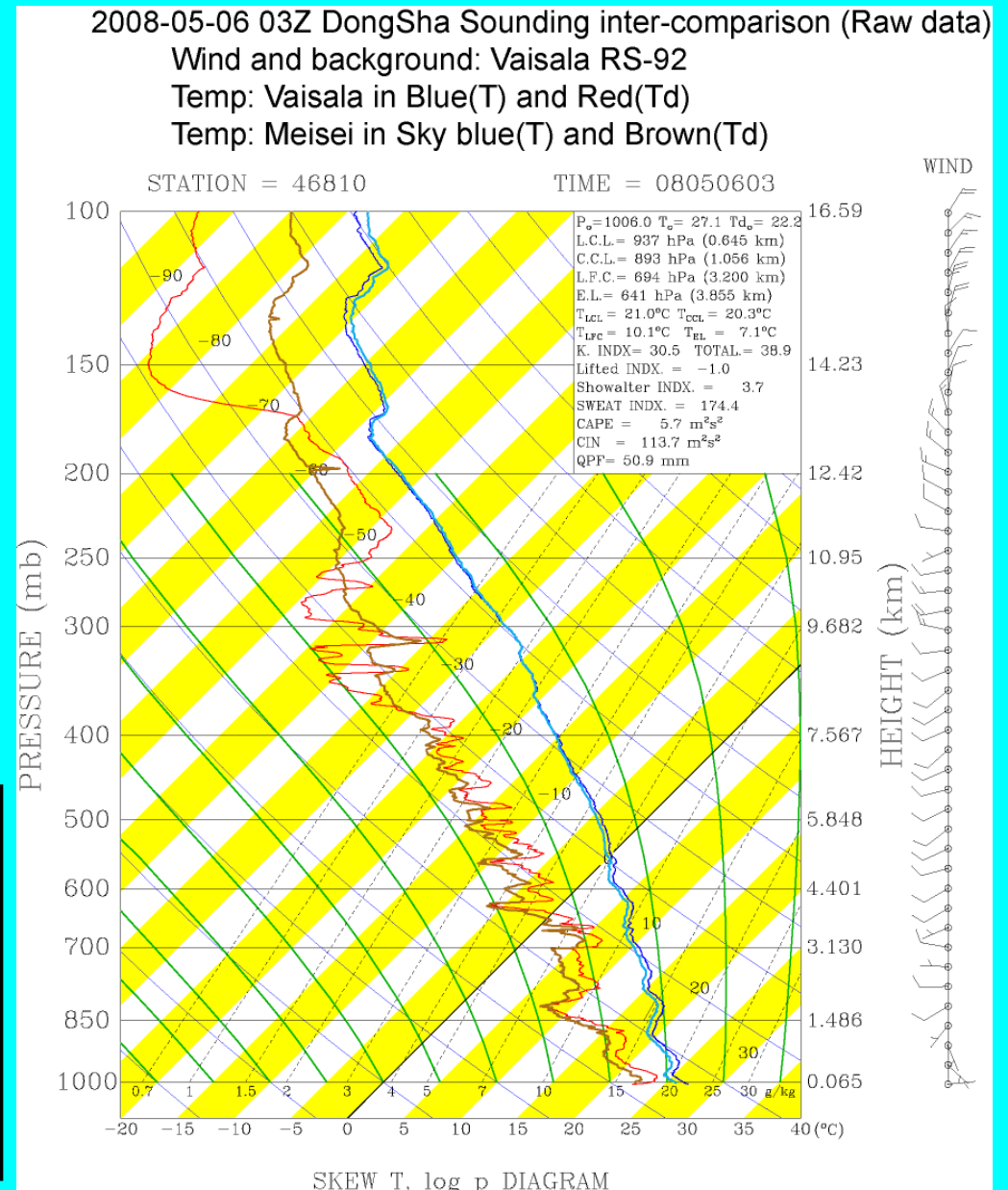

Summary of systematic sonde biases found in recent studies for sonde types to be used in TIMREX

Vaisala RS80A	4% dry bias at all RH (Wang et 2002, Haberli 2006)
Vaisala RS80H	2% dry bias in PW for PW<40 mm (Wang and Zhang 2008)
Vaisala RS92	Daytime dry bias that increases with height (Vomel et al. 2007, Yoneyama et al. 2008)
GRAW	5% dry bias at low-levels (WMO 2001); no PW bias found by Wang and Zhang (2008)
Meisei	Small dry bias at high RH, wet bias at low RH (Nakamura et al. 2004)
Shang	Slight (<1%) moist bias (Wang and Zhang 2008)

Note: the biases for each sonde type are quite general such that large site to site differences exists and need to determine.

WMO study involved an inter-comparison of six GPS sonde systems in May-June 2001 in Brazil. One of the systems used was a Snow White (SW) System; the SW hygrometer measures dew/frost point based on chilled mirror principle and is generally regarded as a reference standard because of its high accuracy.

47 flights were carried out with platforms carrying multiple sonde types. Flights were conducted at 4 times of day and in a variety of weather conditions.

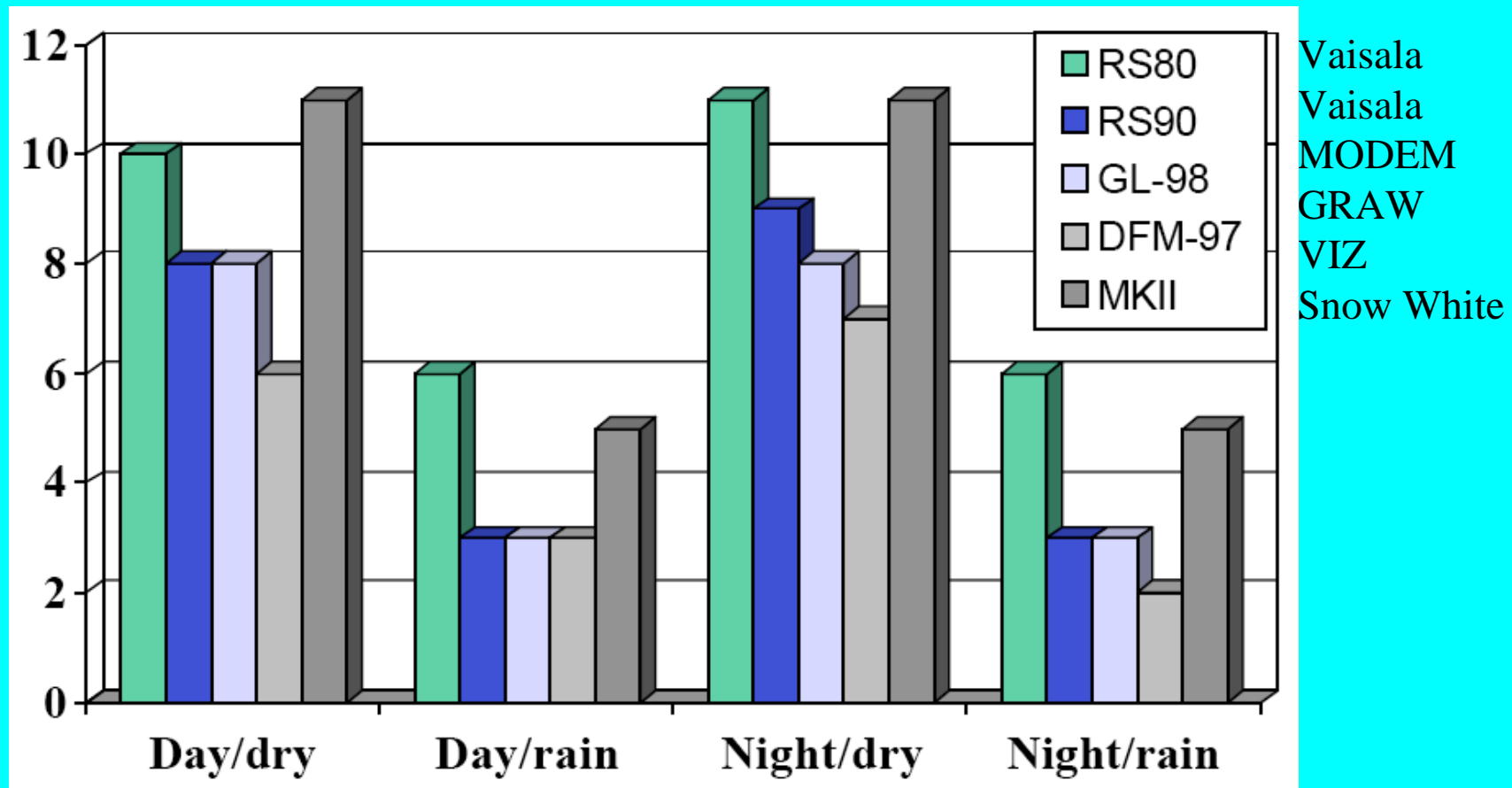

A minimum number of launches (3-6) is needed under a variety of conditions to establish meaningful statistics for a correction scheme.

RS92 - SW

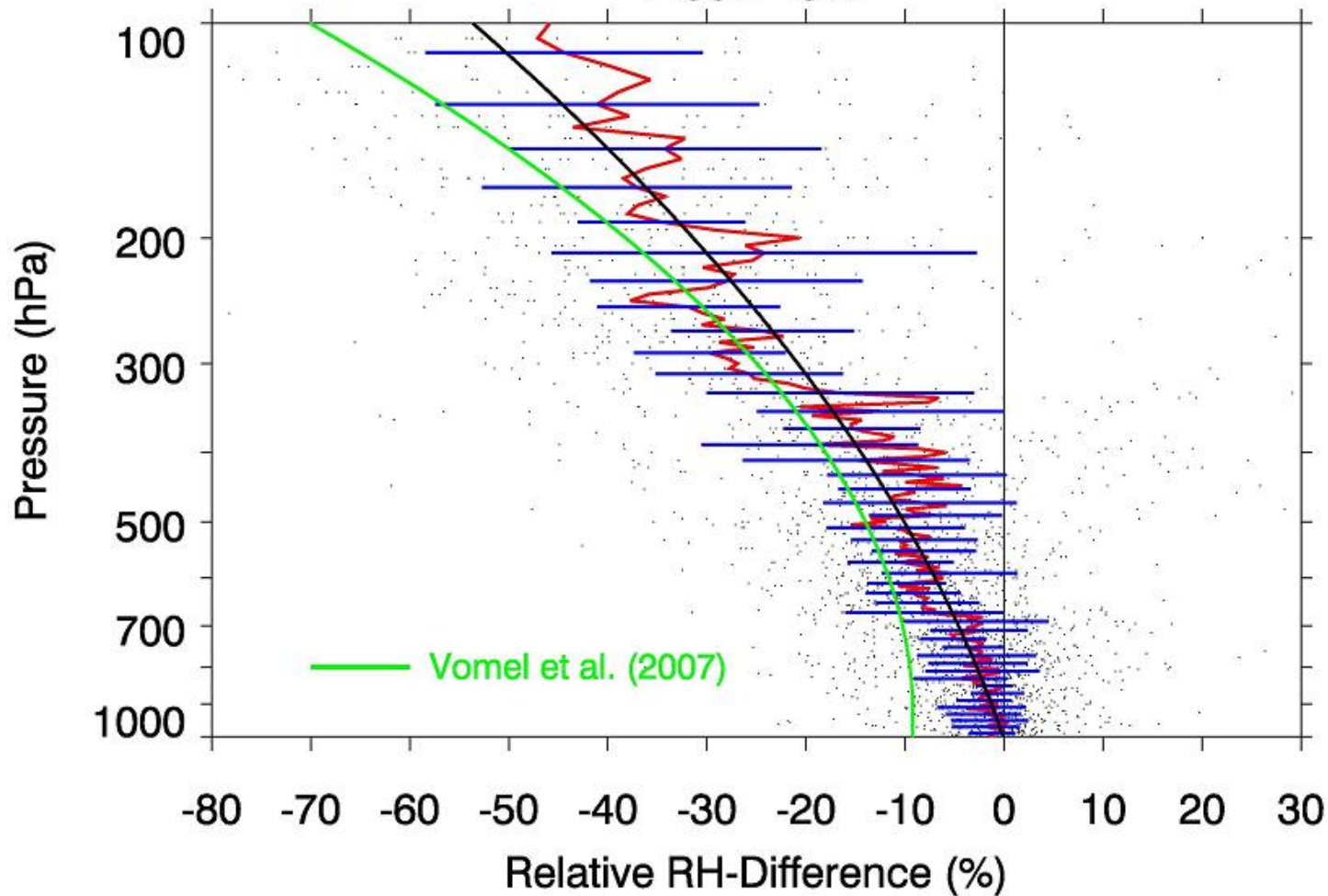

Relative difference between humidity data from RS92 and Snow White (chilled mirror hygrometer) for 14 daytime soundings taken during MISMO in 2006 shows significant dry bias in RS92 sondes, especially at upper levels.

- only CP08 correction is available for VS80 sondes
- several corrections have been proposed for VS92 sondes
- likely the most appropriate correction comes Yoneyama's et al 2009 (YON09) study based on sondes taken in an oceanic, convective environment.

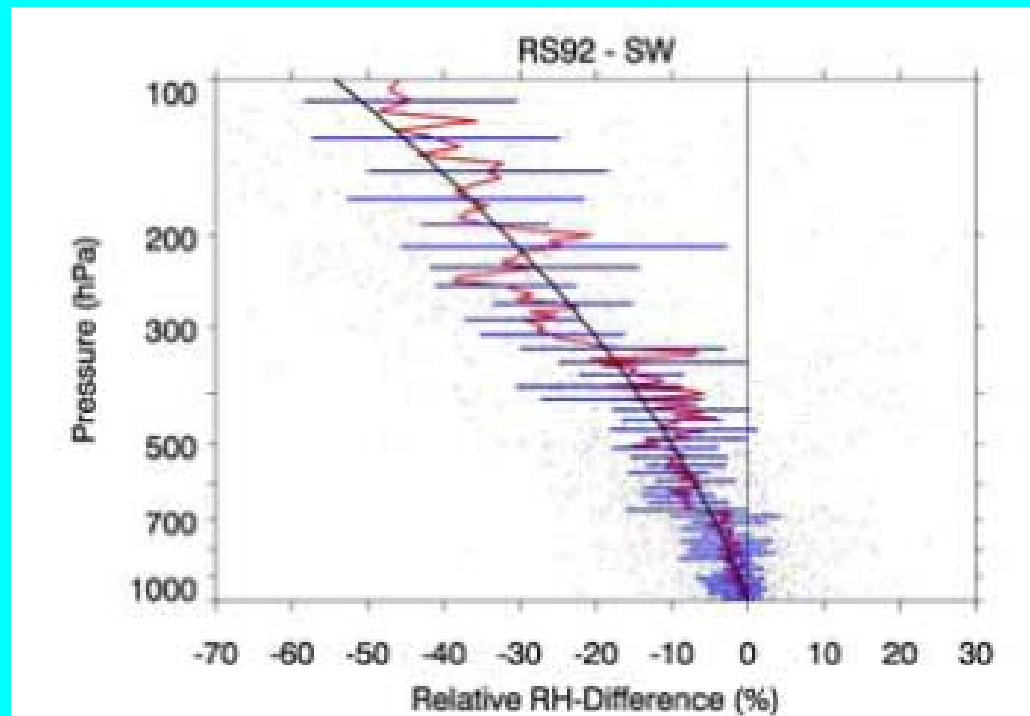

Smooth curve is polynomial fit to red line (RS92-SW RH difference)

$$RH_{dif} = -5.61 (\log P) + 88.17 (\log P) - 341.51$$

Correction is function of solar zenith angle, θ .

$$c = \cos \theta / \cos \theta_m$$

$$RH_{cor} = (100 / (100 + c RH_{dif})) \times RH_{obs}$$

- PW difference (sonde - GPS) before and after correction. Large daytime dry bias is significantly reduced with correction.

- collocating GPS receivers with sonde sites will be helpful in determining sonde moisture biases. Wang and Zhang (2008) recommend that sonde and GPS sites be within 50 km of each other.

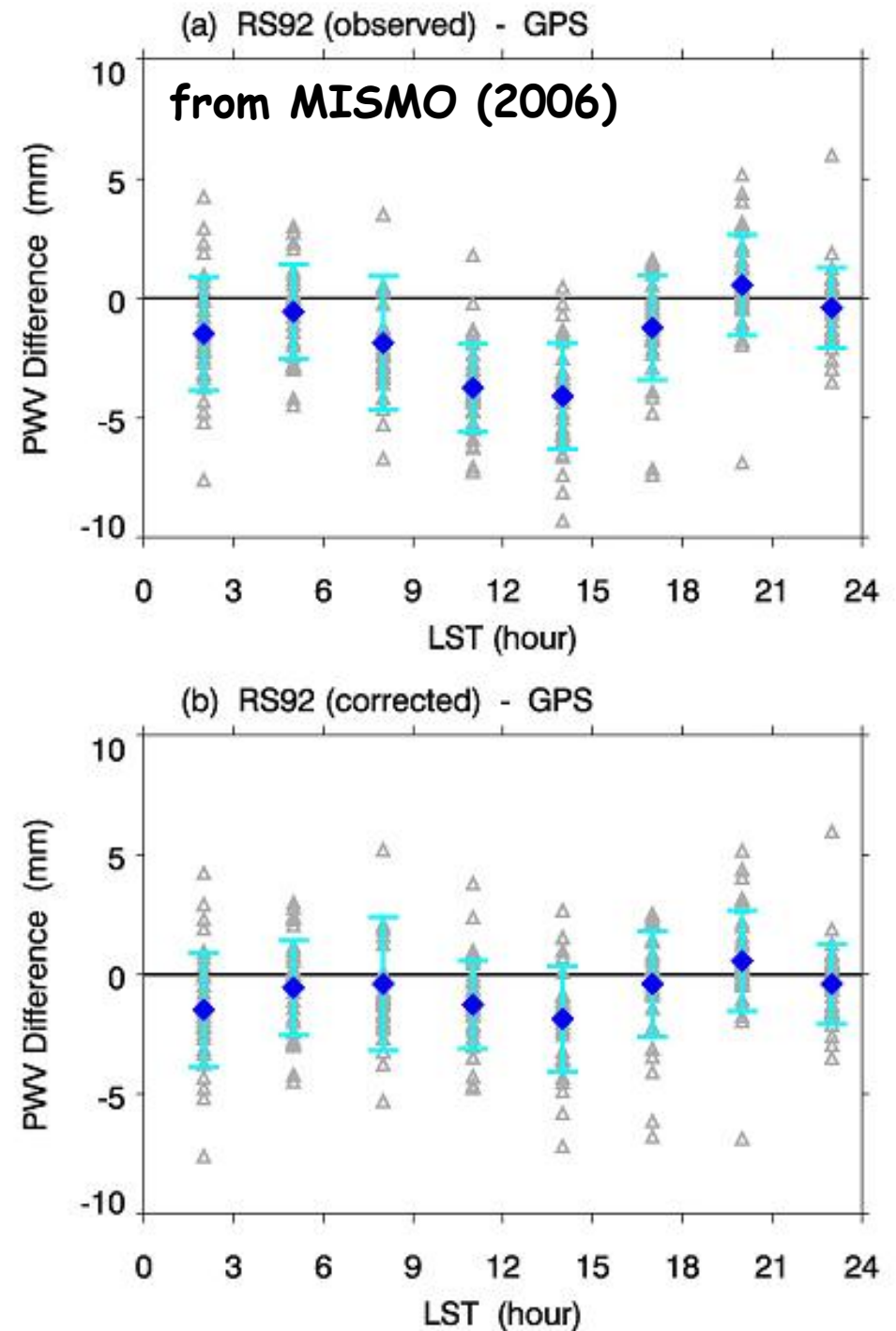

Diurnal Cycle of Sonde PW - GPS PW (mm)

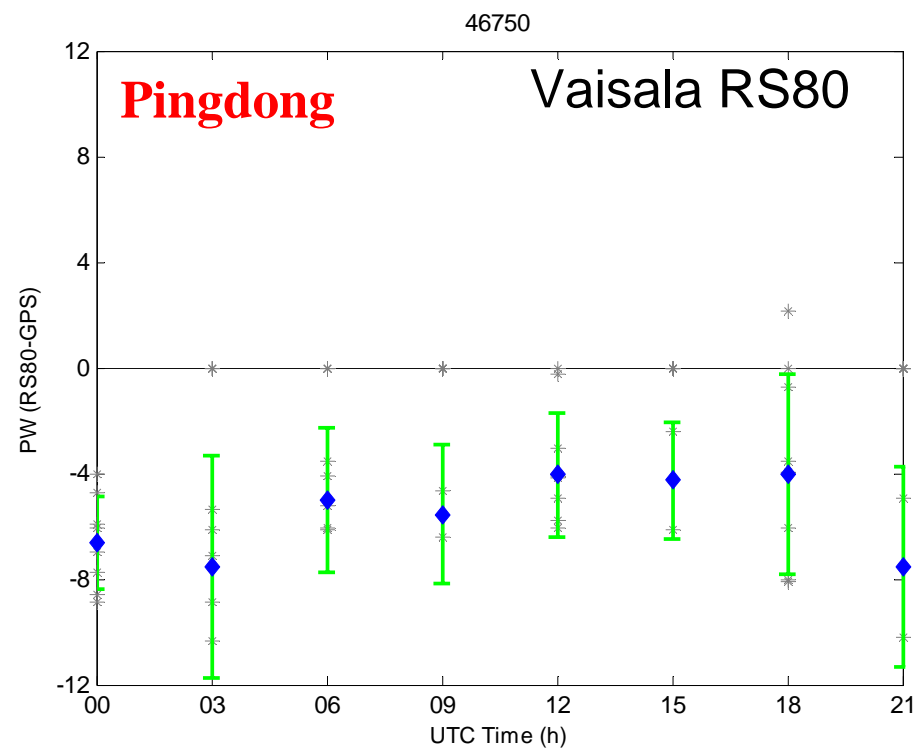
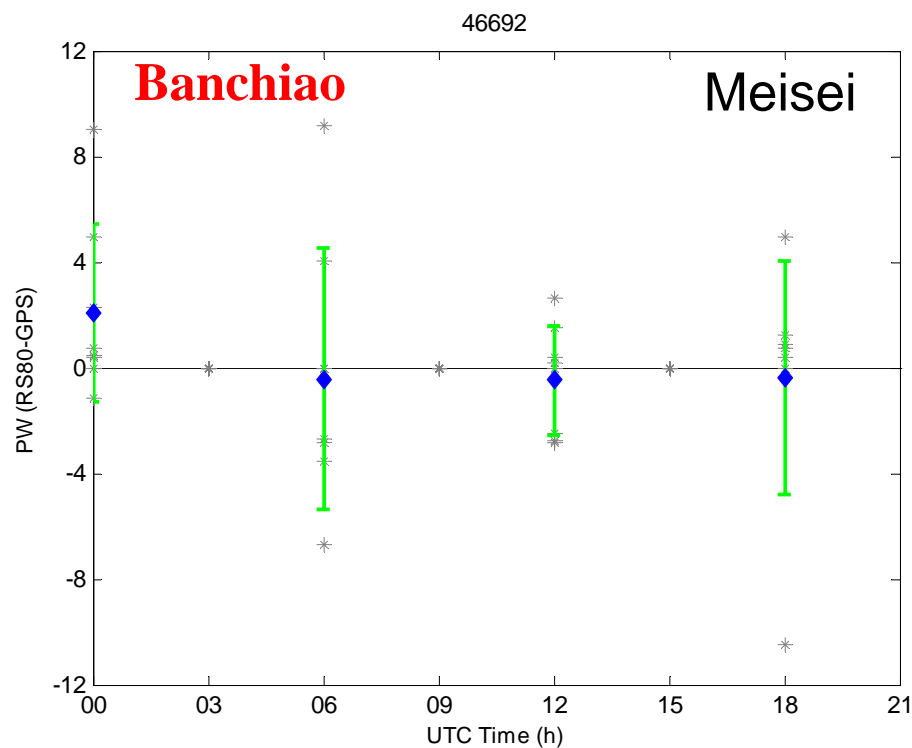

- Negative values indicate that the sonde has a dry bias relative to the GPS estimate.
- Meisei system at Banchiao shows little bias, while Vaisala RS80 system at Pingdong shows significant dry bias which is more prominent during the daytime hours (00 - 09UTC)